

Guidelines on Sanitation for Small Communities

**Appropriate Technologies for Use by Middle-level Technicians
in Countries of the Eastern Mediterranean
Region of World Health Organization**



**World Health Organization
Eastern Mediterranean Regional Office
Centre for Environmental Health Activities
Amman, 1993**

Cover Photo:

Ventilated Improved Pit (VIP) Latrine in Use, Ababda, Aswan , Egypt

In the name of God, the Compassionate, the Merciful

FOREWORD

By

Hussein A. Gezairy, MD, FRCS

Regional Director for the
Eastern Mediterranean Region of
the World Health Organization

Since its inception in 1948, the World Health Organization (WHO), along with the United Nations' Children Fund (UNICEF), has been cooperating with governments interested in the improvement of environmental sanitation in rural areas and small communities. By 1960, three WHO monographs had been prepared, dealing with excrete disposal, water supply and composting of organic wastes in rural areas. There followed a period of about two decades during which WHO's priority in the environmental health field shifted to community (chiefly urban) water supply. However, there has recently been a renewal of interest and concern about the appalling conditions of sanitation frequently encountered in rural areas and small communities of Member Countries.

Several international and bilateral agencies, especially the World Bank, have devoted considerable attention to the study, research and field investigations of present problems, with a view to proposing appropriate technologies and solutions. Most of the publications which have been issued by these agencies are addressed to engineers, social scientists and high-level government administrators of environmental health programmes. Although there has been little change in the basic technologies which have been developed in recent decades, certain cheap construction materials are more readily available (for example, PVC, plastic sheets, fibre cement and fiberglass), thereby increasing the feasibility of some of these excrete disposal technologies.

In many countries of the Eastern Mediterranean Region of WHO, sanitation in rural areas and small communities is often the responsibility of middle-level sanitarians and technicians who act upon their own initiative, without immediate guidance and supervision from sanitary engineers and without the possibility of referral to higher technical levels. Government agencies concerned are invited to elaborate the necessary practical instructions for use by their field staff, preferably in a form and presentation which will facilitate direct application to the solution of local sanitation problems. It is hoped that the present Guidelines may serve as a reference, or perhaps as a model, for this purpose.

These Guidelines have been written with the following objectives:

- 1. To facilitate the work of government health and other administrations concerned with the preparation of practical guides, or instructions, describing appropriate solutions to local sanitation problems, which are acceptable from the social, economic and technologies standpoints.*
- 2. To extract and adapt from past and recent publications the technical information of immediate relevance to the social, economic and physical conditions of the countries of WHO Eastern Mediterranean Region, for the use of middle-level technicians.*

The following considerations limit the scope of these Guidelines:

- 1. Since these Guidelines are intended for use by personnel working in different cultures and physical settings, several of the technologies described may have to be adapted to suit local conditions. The text is written in simple language to make such adaptation possible in most instances by the middle-level technicians themselves.*
- 2. Even though these guidelines might be of value in training middle-level and frontline sanitation workers, they should not be considered as a substitute for text-book on environmental sanitation.*
- 3. In view of the above objectives, there is very little theoretical coverage of either the biological, chemical, sociological or engineering aspects of the subjects covered; the emphasis having been placed on practical and field implementation of sanitation facilities.*

A handwritten signature in black ink, appearing to be 'C. J. B.' with a flourish extending to the right.

ACKNOWLEDGEMENTS

The World Health Organization's Regional Office for the Eastern Mediterranean acknowledges with gratitude the work undertaken by Dr B.B. Sundaresan and Mr J.N. Lanoix who prepared the original manuscript of the manual. Later, the first draft was summarized, abridged and reviewed by Dr M.I. Sheikh, Director, Environmental Health, Mr M.A. Mullick, Regional Adviser, Community Water Supply and Mr T.L. Videnov, WHO Sanitary Engineering Consultant in the Regional Office. The names of the experts who reviewed the second draft are listed below and their support is also gratefully acknowledged.

Special thanks are due to Ms Katherine Wedgewood, Messers Jamie Bartram and Andy Rickards from Robens Institute, University of Surrey, United Kingdom, who reviewed and edited subsequent draft. Finally, acknowledgement is made to Eng. M. Malkawi, CEHA Documentalist, for his assistance in finalization of drawings and document production.

REVIEWERS OF THE SECOND DRAFT

1. Dr B.B. Sundaresan
Former Vice Chancellor,
University of Madras, and
Ex Director, National
Environmental Engineering
Institute (NEERI),
Nagpur, India
2. Dr Bashir M. El Hassan
Associate Professor in
Environmental Engineering,
University of Khartoum,
Sudan
3. Mr Odyor A. Sperandio
Formerly Manager,
(Community Water Supply)
World Health Organization,
Geneva, Switzerland
4. Mr Joseph Landix
Formerly Sanitary Engineer,
World Health Organization,
Geneva, Switzerland
5. Dr Fahmy M. El-Sharkawi
Professor of Sanitary
Engineering, High Institute
of Public Health,
Alexandria, Egypt
6. Mr S.M. Rafi Ahmad
Formerly Managing Director,
Pakistan Environmental
Planning and Architectural
Consultants Ltd.,
Lahore, Pakistan
7. Eng. Obaidullah Siddiqi
Sanitary Engineer,
Saudi Consulting House,
Riyadh, Saudi Arabia

Sanitation Guidelines

GUIDELINES ON SANITATION FOR SMALL COMMUNITIES: APPROPRIATE TECHNOLOGIES FOR USE BY MIDDLE-LEVEL TECHNICIANS IN COUNTRIES OF THE EASTERN MEDITERRANEAN REGION OF WHO

| Table of Contents | Page |
|---|------|
| 1. INTRODUCTION | 1 |
| 1.1 On-site Technologies | 1 |
| 1.2 Off-site Technologies | 2 |
| 2. RECOMMENDED EXCRETA DISPOSAL OPTIONS | 6 |
| 2.1. Latrine Method of Excreta Disposal | 6 |
| 2.1.1. Factors Influencing the Design of Sanitation Facilities | 6 |
| 2.1.2. Pit Latrine and Ventilated Improved Pit Latrine (VIP) | 25 |
| 2.1.3. Reed's Odourless Earth Closet (ROEC) | 58 |
| 2.1.4. Double Vault Compost Latrine (DVC) | 62 |
| 2.2. Water-carried Methods of Excreta Disposal | 68 |
| 2.2.1. Pour-Flush (PF) Toilet | 68 |
| 2.2.2. Aqua Privy | 79 |
| 2.2.3. Septic Tank | 94 |
| 3. OTHER EXCRETA DISPOSAL OPTIONS | 130 |
| 3.1. On-site Technologies | 130 |
| 3.1.1. Borehole Latrine | 130 |
| 3.1.2. Overhung Latrine | 134 |
| 3.2. Off-site Technologies | 135 |
| 3.2.1. Bucket Latrine | 135 |
| 3.2.2. Vault and Cartage Systems | 139 |
| 3.2.3. Communal Sanitation Facilities | 144 |
| 4. LOW COST UNCONVENTIONAL SEWERAGE | 149 |
| 5. BIBLIOGRAPHY | 154 |
| 6. GLOSSARY | 157 |

1. INTRODUCTION

These guidelines are based on existing knowledge. For theoretical background, for information on recent research or field investigations, and for a methodology of environmental health programme planning on a large scale, the reader may wish to consult some of the publications listed in the Bibliography. A good deal of the technical material, including the illustrations, presented in these guidelines originates from these publications. It has been reproduced, or adapted, with their publishers' authorization, for which EMRO is grateful. Use has been made of WHO's own publications and of the valuable comments made by a number of WHO staff members and of outside experts.

There are many problems involved in the selection of the right type of excreta disposal technology for a small community. In planning a permanent solution to an excreta disposal problem, many interrelated factors must be considered. These include cultural patterns, religious customs, hydrological and geological conditions, economic aspects, political and social organization of the community, general and health education, skills of local population, the availability of construction materials and personnel for technical supervision. What may appear on the surface to be a simple problem has often, upon more careful examination, been found to be a relatively complex one.

Generally, the process of selecting the appropriate technology begins with an examination of all of the alternatives available.

The following types of sanitation facilities are presented in these Guidelines for use by the middle-level sanitation technicians in countries of the Eastern Mediterranean Region of W.H.O:

1.1 On-site Technologies

1. Pit Latrine
2. Ventilated Improved Pit Latrine (VIP) formerly known as Sanitary Pit Latrine
3. Reed's Odourless Earth Closet (ROEC);
4. Borehole Latrine

Sanitation Guidelines

5. Compost Latrine
6. Aqua Privy
7. Pour-flush Latrine (PF), also known as Water-seal Latrine;
8. Septic Tank

1.2. Off-site Technologies

1. Bucket Latrine
2. Vault and cartage Systems
3. Communal Sanitation Facilities

These technology options are discussed in Parts 2. and 3. of the Guidelines which, in addition, discuss briefly the problems of sullage disposal and of reuse of excreta.

Usually, there will be some technologies that can be readily excluded for technical or social reasons. For example, septic tanks requiring large drainfields would be technically inappropriate for a site with a high population and housing density. Similarly, a composting latrine would be socially inappropriate for people who have strong cultural objections to the sight or handling of excreta. Inappropriate sanitary options can easily be eliminated by ensuring the active participation of the community in the early planning stage of the project. This process can be greatly assisted by collecting relevant information through the application of a sociocultural and sanitary survey.

The selection process must take into account the cost element. Cost estimates must be prepared for the types of latrines under consideration. Water-carried sewerage systems with flush toilets are very expensive and generally beyond the economic possibilities of small communities. At the other extreme, it is possible for everyone to relieve themselves in the most primitive manner at no immediate cost whatsoever. However, such behaviour is insanitary and represents a high public health risk, which can have enormous economic repercussions. Between these extremes a solution should be sought that will maximise health protection, be within the economic capacity of the people and not conflict with their cultural attitudes.

Every sanitation worker should carefully consider the economic aspects of the problem, not only as they apply to latrines, but also as they relate to other

Sanitation Guidelines

types of sanitary improvement. At the community level, the health and other agencies concerned, through sanitation technicians, should assist each family in finding and implementing the most appropriate solution. It is difficult to prepare cost estimates for projects that are new and drawn up mostly from unreliable information. The cost estimate should be realistic, honest, and correct. If the basic data are poor or incomplete, this should be made abundantly clear to those officials who will decide on budget matters. In this instance, it is wise to include generous allowances for unknown factors such as soil conditions. The total sum required may appear large, but is much better in the long run to accept the more difficult job of promoting a sanitation project that seems to be expensive beforehand than try to justify a budget increase halfway through its implementation.

There is a great variety of excreta disposal methods from which to make a choice. However, in selecting or designing a type of latrine cost should not be the dominant factor. It is necessary to strike a balance after careful consideration of all the factors involved. Preference should be given to those factors which are conducive to a sanitary environment and provide an acceptable level of service at minimum cost.

From a purely technical and sanitary standpoint, the sanitation facility selected should satisfy the following requirements:

1. The soil surface should not be contaminated.
2. There should be no contamination of ground water that might enter springs and wells.
3. There should be no contamination of surface water.
4. Excreta should not be accessible to flies or animals.
5. There should be no handling of fresh excreta; or, when this is unavoidable, it should be kept to a strict minimum and certain precautions applied.
6. The system should be free from odours or unsightly conditions.
7. The method used should be simple and inexpensive to construct, operate and maintain.

Sanitation Guidelines

In addition to these criteria, the choice of installation must be made in the light of:

8. What the community needs and is prepared to accept.
9. What the community can afford.
10. What the community can maintain in the future.

The words that should describe the design chosen are *appropriateness* and *soundness*. They do not mean luxurious or poor, expensive or cheap. They do mean the best possible technology at a cost which the particular community, or family, can afford.

Once a tentative selection of the most appropriate technology has been made, several check questions should be asked again:

1. Do the intended beneficiaries really want sanitation?
2. Is the technology selected socially acceptable?
Is it compatible with cultural and religious requirements?
3. Can it be maintained by the user? Are community-support services (e.g. for health education, or sanitary inspection) required?
Can these be provided?
4. Have beneficiaries been involved in deciding where latrines will be located? Are the planned sharing arrangements (if any) acceptable to beneficiaries?
5. Are the beneficiaries able and willing to pay the full cost of the proposed facility? If not, are user subsidies (direct grants, or loans) wanted and available?
6. Are the beneficiaries able and willing to contribute labour and/or materials for the construction of the sanitation facility?
7. Are special equipment, or skills, required for the technology? If lacking, can they be developed?

Sanitation Guidelines

8. What is the potential for reuse? Is reuse of wastes desirable and economically feasible?
9. If the selected technology cannot deal with sillage, what facilities for sillage disposal are required.

2. RECOMMENDED EXCRETA DISPOSAL OPTIONS

2.1. Latrine Method of Excreta Disposal

A rational approach is based on at least a minimum knowledge and understanding of the fundamental biological and physical factors involved in excreta disposal. It is assumed that the sanitation technician already possesses the relevant education and knowledge. Therefore, only a brief reminder of the most significant factors which influence the design of sanitation facilities are outlined below. The text is written as simply as possible.

2.1.1. Factors Influencing the Design of Sanitation Facilities

(a) Biological Considerations

Excreta, wherever deposited, immediately start to decompose. After a period of time they are ultimately converted to an inodorous, inoffensive, and stable product. In the design of excreta disposal facilities it is important for the health worker to know and understand how this process takes place, and how it affects the material itself and the disease causing organisms (pathogens) such material may contain. The sanitation technician is often called upon to explain in simple terms what actually happens to faeces and the health hazards involved in inadequate disposal systems.

The main actions of decomposition are:

- (i) to break down complex organic compounds into simple and more stable products in the form of liquid, gas and reduced solids;
- (ii) to reduce the volume and mass (sometimes as much as 80%) of the decomposing material by the production of gases (such as methane, carbon dioxide, ammonia, and nitrogen) which are dissipated into the atmosphere, and by the production of soluble materials which, under some circumstances, leach away into the underlying soil; and

Sanitation Guidelines

(iii) to destroy those pathogenic organisms which are unable to survive the processes of decomposition or attack by other biological organisms present in the decomposing mass.

Bacteria play the major role in decomposition of excreta and other organic wastes, whether in latrines, aqua privies, septic tanks or compost piles. Bacterial action may either be aerobic - i.e., carried out in the presence of air - or anaerobic - i.e., carried out in the absence of oxygen. In a fluid such as the contents of a septic tank the process will generally be anaerobic, as it is in aqua privies, or at the bottom of deep pits. Alternatively, it may be aerobic, as in certain composting operations. Decomposition may also occur as a result of more than one stage, some anaerobic and some aerobic, depending upon the physical conditions encountered. For example, anaerobic processes may take place in a septic tank; but as the liquid effluent is discharged into an underground tile distribution system, the water drains away leaving much organic matter in the upper layers of the soil to be decomposed by aerobic saprophytic bacteria, which thrive in the top 60 cms. of the soil. Human wastes, (a mixture of faeces and urine), are relatively rich in nitrogenous compounds whose decomposition follows part of the "nitrogen cycle" (see Figure 1). In an initial stage - putrefaction - odorous gases are released. This is followed by oxidation in which nitrogenous materials are converted to stable forms. The strong odours noted during the decomposition of urine are due to ammonia which escapes upward before it is converted into a more stable form.

The rate at which decomposition takes place depends on conditions of temperature, moisture, aeration and the nature of the decomposing mass. The time required can vary from a few days for carefully controlled composting to about year under average conditions in a pit latrine.

Conditions prevailing in decomposing faeces are generally unfavourable to the survival of pathogenic organisms. Not only do temperature and moisture conditions inhibit the growth of pathogens, but predatory micro-organisms are present. Bacterial pathogens tend to die quickly when the humus-like end product of decomposition is spread out and dries. Bacterial pathogens probably do not survive more than two months in undisturbed latrine contents. However, ova of hookworm will remain viable for much longer periods. Depending on moisture and air temperature, ova may live up to five months (eg. in cool climates), but this period is substantially reduced under tropical conditions. They will eventually hatch in the presence of air and will produce larvae which may survive for several weeks in moist, sandy soil. *Ascaris* ova may live for two weeks or two to three months in pit latrine material.

Fig. 1. THE NITROGEN CYCLE

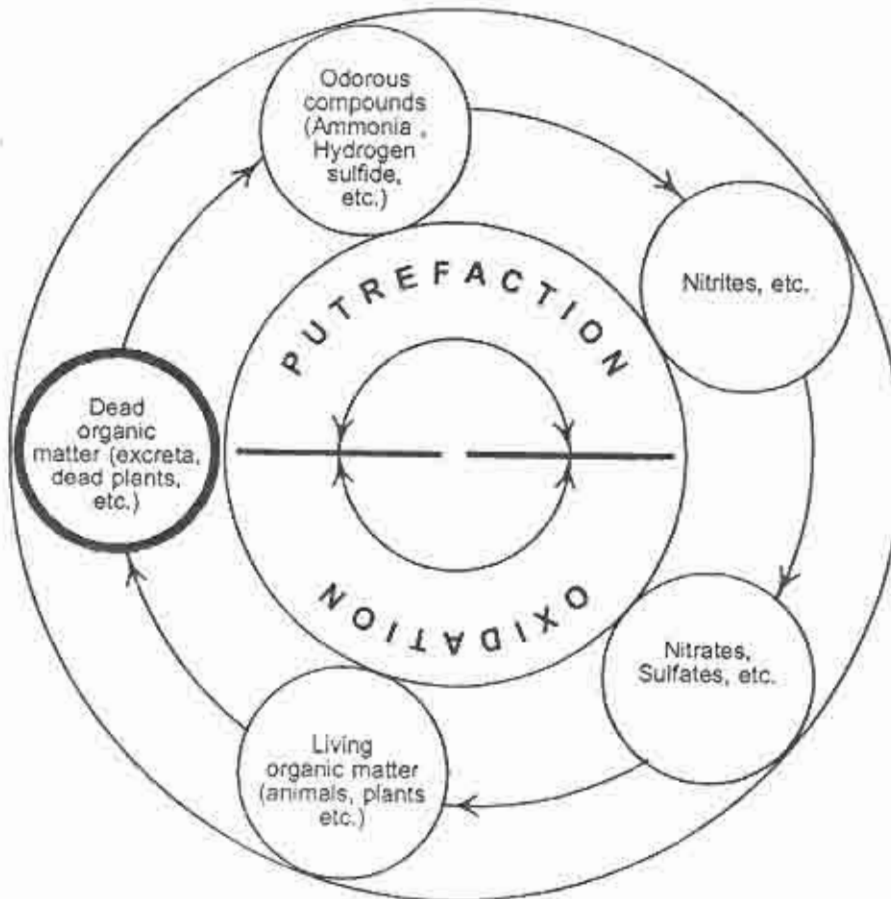

The final products of decomposition are a valuable soil conditioner and contain soil nutrients. They may profitably be used as fertilizers. Some farmers complain of the small nitrogen content of digested or composted excreta. Indeed, fresh excreta do contain more nitrogenous matter. However, plants can utilize nitrogen only as ammonia, nitrites or nitrates, which are only produced during later stages of decomposition. Thus, when raw excreta are spread on the land, much of the nitrogen is transformed into volatile matter, which evaporates into the air instead of being used by plants.

Sanitation Guidelines

(b) Soil and Groundwater Pollution

The study of pollution of soil and water by excreta provides useful information concerning the design of disposal facilities, especially their location with respect to sources of drinking water supplies. After excreta are deposited on the ground or in pits, the bacteria, unable to move much by themselves, may be transported horizontally and vertically downwards into the ground by leaching liquids, such as urine or rain water. The distance travelled by bacteria in this way varies with several factors, the most important of which is the porosity of the soil (see Figs. 2,3, and 4). Their horizontal travel through soil in this manner is usually less than 90 cm. The downward distance travelled is less than 3 m in pits open to heavy rains, and normally not more than 60 cm in porous soils.

Figure 3 shows the results of studies where the source of contamination was human excreta placed in a hole which penetrated the ground water table. Samples positive for coliform organisms were picked up quite soon between 4 m and 6 m from the source of contamination. The area of contamination widened out to a width of approximately 2 m at a point about 5 m from the privy and tapered off at about 11 m. Contamination did not move "upstream" or against the direction of flow of the ground water. After a few months the soil around the privy became clogged, and positive samples could be picked up at only 2 m to 3 m from the pit. In other words, the area of soil contamination had shrunk.

The chemical pollution pattern is similar in shape to that of bacterial pollution but extends to much greater distances.

From the point of view of sanitation, the interest is in the maximum migrations and the fact the direction of migration is always that of the flow of ground water. In locating wells, it must be remembered that the water within the circle of influence of the well flows towards the well. No part of the area of chemical or bacterial contamination may be within reach of the circle of influence of the well.

Fig. 2. MOVEMENT OF POLLUTION IN DRY SOIL.

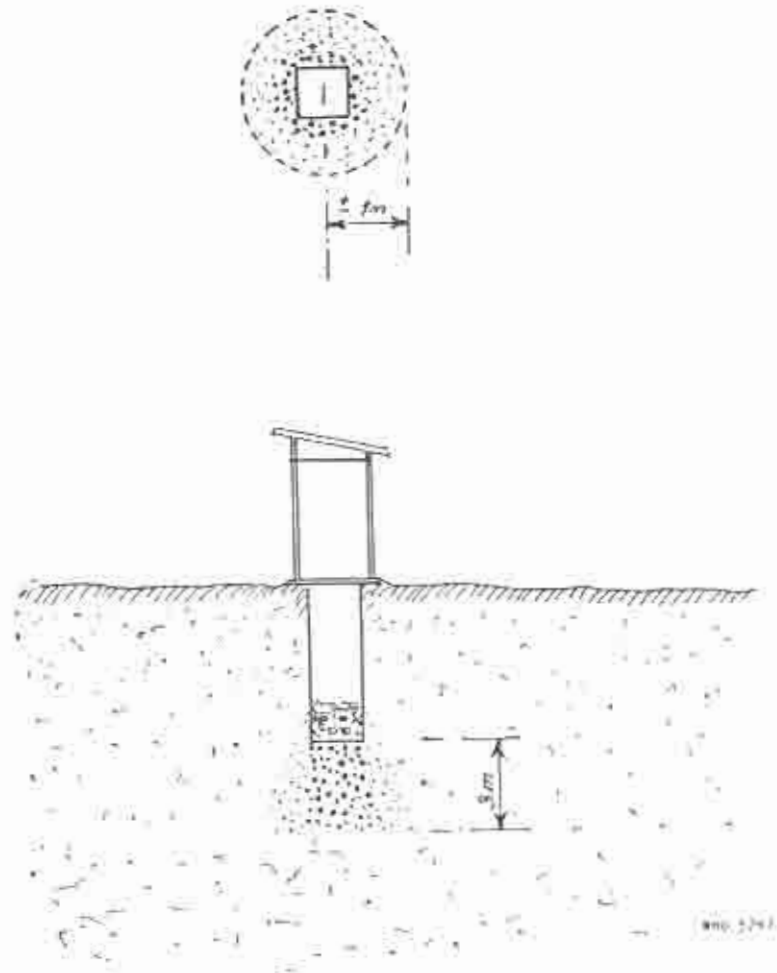

Fig. 3. BACTERIAL AND CHEMICAL POLLUTION PATTERNS AND MAXIMUM MIGRATIONS

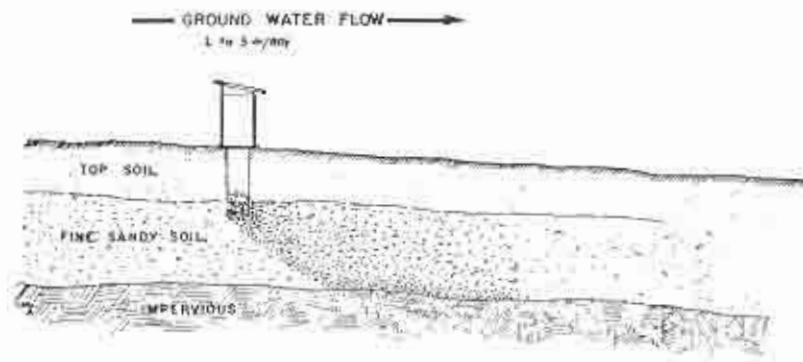
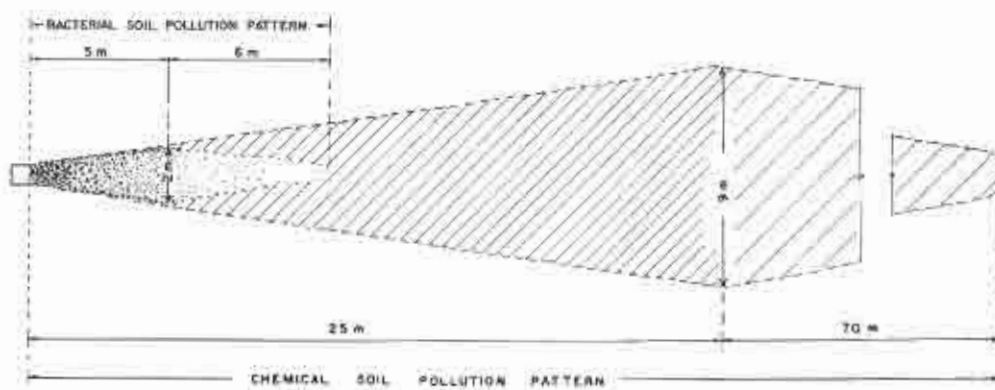
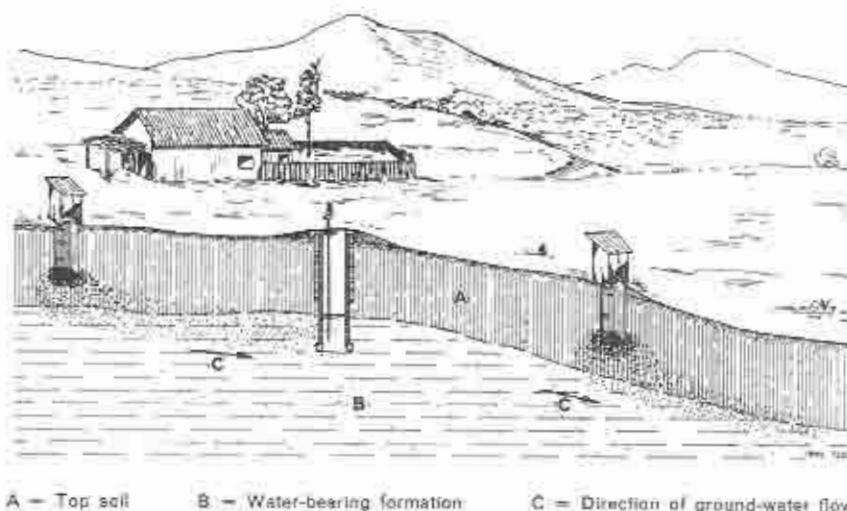

Fig. 4. MOVEMENT OF POLLUTION IN UNDERGROUND WATER



Hookworm larvae, although unable to move through the soil in a horizontal direction to any appreciable extent, are able to climb upward along the pit walls and reach the top surface of defective wooden or earthen floors, where they may infect a person with bare feet.

Depending upon conditions of humidity and temperature, pathogenic bacteria and ova of parasitic worms will survive for varying lengths of time in the ground. Pathogenic bacteria do not usually find the soil to be a suitable environment for their multiplication, and will die within a few days. On the other hand, hookworm ova will survive as many as five months in wet, sandy soil, and three months in sewage.

Hookworm disease is transmitted through contact of the skin, usually bare feet, with soil containing hookworm larvae. Other parasitic diseases may be transmitted when fresh faeces or sewage is used to fertilize vegetable crops which are subsequently eaten raw.

Sanitation Guidelines

If groundwater is located near a source of pollution within the distances mentioned above, it may become contaminated by harmful bacteria and by chemical substances which originate from faecal decomposition. A source of pollution may be excreta deposited on the ground, a pit latrine, a cesspool, or a leaky sewer pipe. The contaminated groundwater, which is usually close to the surface, may be tapped by a well used for drinking water and other domestic purposes. Consumption of this contaminated water may lead to human infection and diseases such as diarrhoeas, typhoid and paratyphoid, hepatitis A, cholera and the dysenteries and schistosomiasis.

(c) Location of latrines

(i) In view of what has been said above, it is extremely important to locate a latrine or cesspool remote and generally downhill from a well. Where uphill locations cannot be avoided, a distance of 20 m will normally prevent bacterial pollution of the well. Setting the latrine off to either the right or the left would reduce the possibility of contaminating the ground water reaching the well.

(ii) In most soils the chance of groundwater pollution is virtually nil if the bottom of a latrine is more than 1.5m above the groundwater table. The same may be said if the bottom of a cesspool is more than 3 m above the level of the ground water.

(iii) A careful investigation should be made before building pit latrines, borehole latrines, cesspools and seepage pits in areas containing fissured rocks or limestone formations, since pollution may be carried directly through channels in the rock to distant wells or other sources of drinking water supplies.

(iv) A latrine should not be located closer than 20 m to the nearest water course. Regarding the location of latrines with respect to dwellings, experience shows that the distance between the two is an important consideration in the acceptability of sanitary facilities. The location of latrines, private or communal, at a considerable distance and/or uphill from dwellings reduces the likelihood of their being regularly used and properly maintained. A latrine is more likely to be kept clean if it is close to the house or other building which it serves. However, a minimum distance of 6 m is desirable. Fig. 5 gives an example of proper location of latrines with respect to wells and dwellings.

Fig. 5. WELL AND LATRINE LOCATION IN A TYPICAL RURAL COMMUNITY

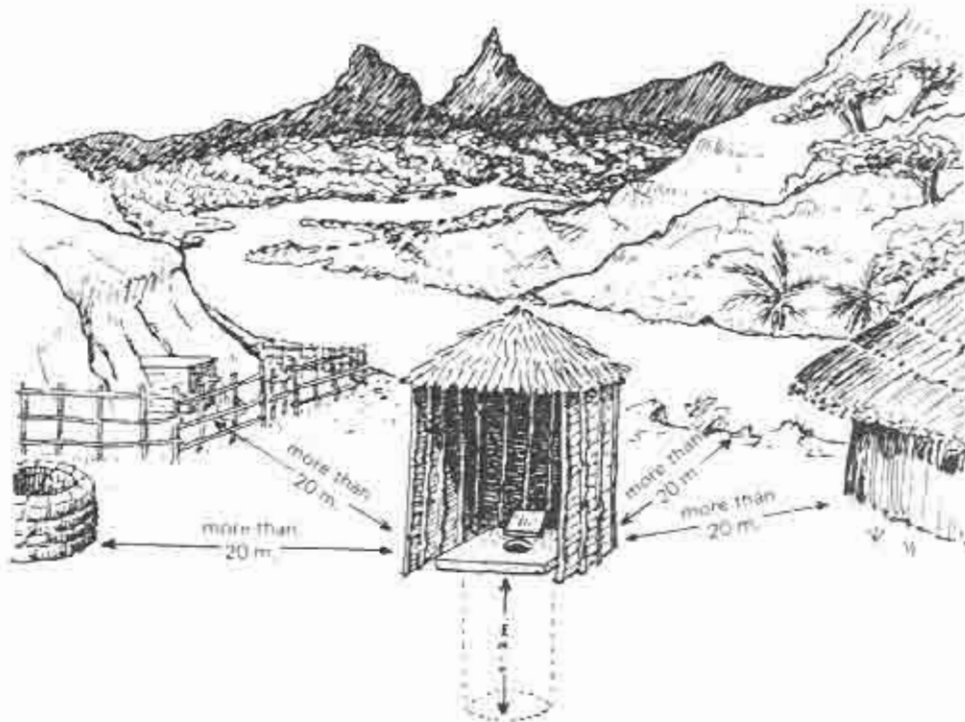

Other considerations are:

- (v) The site should be dry, well drained, and above flood level.
- (vi) The immediate surroundings of the latrine, i.e., an area 2 m wide around the structure, should be kept clear of wastes, and other debris, and vegetation should be regularly cut back. This recommendation may be ignored, however, in the initial stages of sanitary development of rural areas where it is necessary, for example, in order to secure acceptability of the latrine by the local population, to avoid disturbing the natural bush-type surroundings which were previously used for defaecation.
- (d) Reuse Potential of Excreta

In areas where human and animal excreta have traditionally been used in

Sanitation Guidelines

agriculture, material from latrines and sludge from aqua privies and septic tanks can be applied as a soil conditioner and fertilizer. The pits must not be used for 12 months or more prior to the removal of the material. Alternatively, proper composting must be ensured. The feasibility and the sanitary aspects of such a scheme must be thoroughly and realistically examined. In areas where excreta reuse is not a traditional practice it is unlikely to become acceptable and small-scale testing should be carried out.

(e) Anal cleansing materials

The type of material used for anal cleansing affects the size of latrine pits and the design of effluent disposal systems. In some rural areas, the materials used, e.g. stones and mud balls, are not degradable, and they fill up the pits rapidly. The same applies to aqua privies, the operation of which depends, over time, in the reduction of decomposable excreta. In such instances the capacity of latrine pits and aqua privies may need to be substantially increased. In other areas, maize cobs, stones and cement bag paper clog the water seal of pour-flush toilets and prevent their operation. The use of water for anal cleansing presents problems for compost latrines only, whose contents may become too wet for efficient composting.

(f) Fly breeding

The role of flies in the transmission of faecal-borne diseases is very important. The common housefly lays its eggs by preference in horse and stable manure, but will also do so in exposed human excrement and any other decaying organic matter. The fly crawls and feeds on this material, picking up microorganisms on its hairy body, as well as bacteria which pass unharmed through its alimentary tract and are often deposited later on human food. Besides the housefly, various other flies (e.g., bluebottles and greenbottles) may also breed in human excrement and decaying matter. In temperate climates, excreta-borne diseases are usually more prevalent during the warmer months when flies are more numerous and most active.

In designing a latrine, attention must be paid to means of preventing fly contact with excreta and fly breeding. In so doing advantage may be taken of the fact that flies are attracted by light and avoid darkness and dark surfaces. The best latrine is one in which the excreta are promptly flushed away into a closed pit or tank. Other types of latrine would also be effective in this respect if all openings leading to the excreta, including the seat, were kept clean and closed when not in actual use. This is not usually the case.

Sanitation Guidelines

Attempts have been made to attract and trap flies which have hatched in latrine pits. These attempts have apparently not been successful, as the mechanisms involved (inverted glass bottle, perforated cans, or others) do not seem to last or stay in place very long.

Disinfectants should not be used in pit latrines. They are quickly neutralized by the organic matter and interfere with decomposition.

Certain chemicals may be added periodically to latrines as larvicides to control fly breeding. Their application requires careful monitoring and entomological supervision. Furthermore, their repeated application tends to make them expensive in the long run and will interfere with the biological system. For these reasons chemicals are not considered in these guidelines.

(g) Hole covers

The subject of a cover for the hole in a latrine slab, or for a seat, is an interesting but controversial point in the design of latrines. There is no doubt that a cover is desirable, and in some places necessary, to prevent ingress of flies and other vermin and to reduce odours.

In addition, depending on the type of latrine superstructure, a cover will help to prevent entrance of light and sun rays into the pit and will help keep the pit in darkness.

Self-closing covers have not been successful because the condensation which takes place on the underside of a closed seat is objectionable to the users. Covers that are hinged to the slab or seat riser are usually left in the open position. Covers not hinged to the slab are seldom replaced on the hole and are soon carried away by children. Hinges of even the most rugged design are soon broken. People quickly get rid of covers which lean on their backs or which become infested with fireants or other vermin.

In view of the above, the illustrations in these guidelines do not include seat or hole covers, except figure 6 which shows a simple type of cover, the use of which may be promoted by the local sanitation worker as part of a long-term health education effort, especially in communities where flies are abundant.

Fig. 6. SIMPLE HOLE COVER

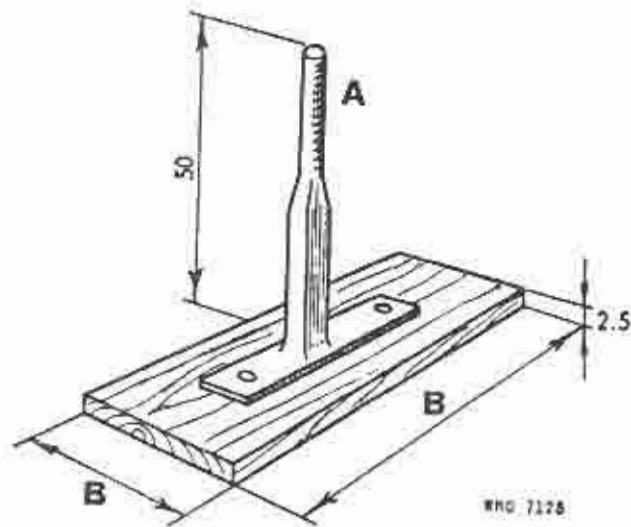

A = Long handle is a special feature. Top part is likely to remain clean

B = Width and length to suit size and shape which will be covered, not plugged.

Measurements shown are in centimeters

(h) Pit and tank ventilation

As mentioned above, the putrefaction of excreta and urine produces foul-smelling gases which may invade the latrine's superstructure through the hole in the slab, and which are objectionable to users. This is the case in the traditional pit privy. In the 1920s efforts were made in some countries to alleviate this problem by installing, behind the hole or seat riser, a small-diameter vent pipe which rose up through the superstructure's roof and was capped by metal screen. The vent pipe was made of thin galvanized iron sheets which rust rather quickly because of the corrosive nature of the gases produced. When provided with a seat (or hole) cover and a

Sanitation Guidelines

vent pipe, the traditional pit latrine became the "Sanitary Pit Privy" which was considered to fulfil all seven sanitary requirements listed in the Introduction.

Following recent field investigation in southern Africa, the "Sanitary Pit Privy", under the new name of "Ventilated Improved Pit (VIP) Latrine", has been confirmed, with minor modifications, to be the latrine of choice for many rural and small communities. These investigations have shown that the principal mechanism inducing ventilation in VIP latrines is the action of the wind blowing across the top of the vent pipe, which must therefore be well above the level of the latrine roof. The wind effectively sucks air out of the vent pipe which is replaced from the atmosphere via the latrine superstructure and squat-hole. Consequently there is a circulation of air from outside the latrine, through the superstructure and squat-hole, up and out of the vent pipe. Thus, any odours from the faecal material in the pit are exhausted via the vent pipe, and not via the squat-hole. As a result the superstructure remains odour-free.

An earlier explanation for the cause of ventilation was that the vent pipe absorbed heat from the sun and transferred some of this energy to the air inside the vent pipe, which consequently became less dense than the outside air immediately above it. It therefore rose out of the vent pipe and was replaced by air below, so establishing the air circulation pattern described above. Fieldwork done in Botswana and Zimbabwe showed that the shearing action of the wind and its direction relative to any openings (doorways, etc.) in the superstructure were much more important than the absorption of solar energy, except under very low wind conditions.

If the superstructure openings (doorways, etc.) face into the prevailing wind, the resulting increased air pressure within the superstructure increases the flow of air up the vent pipe helping to control odours in the latrine; the latrine should therefore be designed so that any openings face the prevailing wind.

These findings apply to the ventilation of pits or tanks of all types of latrines. It has always been the practice to provide vent pipes for aqua privies, pour-flush toilets and septic tank systems. The development in recent decades of new piping materials such as fibre cement (FC), polyvinyl chloride (PVC) and polyethylene (PE), now commonly available in many developing countries, should help simplify latrine ventilation. Vent pipes may also be built of local materials, such as bricks, blockwork, cement-rendered reeds and cement-rendered hessian supported on steel mesh. Recommended vent pipe dimensions are indicated in the description given for each type of latrine.

Sanitation Guidelines

(i) Housing density

In many rural areas, dwellings are dispersed or are located within compounds with plenty of ground space between the structures. In such places, VIP latrines, Reed's Odourless Earth Closets (ROEC), and compost latrines are technically feasible. So are aquaprivies, pour-flush (PF) toilets and septic tank systems if dwellings have an adequate water supply. In some countries, such as rural Egypt or Yemen, small communities are concentrated in a limited area, housing is dense and the space available for household sanitation facilities is at a premium. From a purely technical point of view, the selection of the appropriate type(s) of latrine can be complex, especially in areas such as the Nile Delta where the groundwater table is often only a metre below the surface. The choice of facility may vary from house to house or from village to village, depending upon particular circumstances.

It is impossible to define at what population density on-site systems such as VIP latrines, ROEC, PF and composting latrines are no longer feasible. Preference should be given to the type of latrine which will last longest, ideally, not less than 5 years, before emptying or relocation is required.

(j) Communal versus individual latrines

Communal, or public, latrines are usually constructed in markets, camps, schools, factories, urban poor districts, and similar localities. They are also useful in places where large number of persons congregate occasionally, such as sites of religious pilgrimage, provided that permanent and close attention is available to ensure cleanliness and proper operation.

It is obviously cheaper and easier to construct a few communal latrines in a community than to build a large number of individual household latrines. Furthermore, an appropriate solution to each family's excreta disposal problem is not always easy to find. For such reasons, the construction of communal excreta disposal facilities has been common practice.

However, experience indicates that, except in unusual circumstances, multiple units should never be substituted for the individual family latrine. The reasons for the failure of communal latrines are many and various.

In general, communal latrines are found to be used by only a portion of the population for which they were intended; the remaining population may continue their original practice. Where this is indiscriminate defaecation then the public

Sanitation Guidelines

health risk has not been significantly reduced. The reasons for this situation appear to be due to inadequate design and/or the lack of cleanliness. However, in most instances, where attempts have been made to improve these elements, communal latrines, irrespective of design, have failed to solve the sanitation problems in the community.

The community is generally expected to be responsible for the maintenance of community latrines. Generally, such community administrations of public sanitation facilities are ineffective in ensuring maintenance. There is little likelihood of achieving adequate operation and maintenance of communal latrines, which many people do not consider essential.

The above does not mean that construction of public latrines should be disregarded; but one should be aware of their limitations and of the limited success of projects depending on maintenance by the community. It is often the case that communal authorities require as much as, or considerably greater, pressure than individual families to ensure effective maintenance.

Public latrines should therefore be built only where absolutely necessary or where experience has shown that they are maintained by the community. They should be designed to facilitate maintenance and wherever possible be permanent constructions. Unless cleanliness is observed, they will not be used and they must therefore be kept clean at all times. Water and other materials should be constantly available for use in keeping the latrines clean.

(k) Human factors

In all matters of excreta disposal, human factors are at least as important as technical features. Most of them have been outlined in the Introduction of these guidelines. Two remaining factors affecting the design of sanitation facilities are privacy and separation of facilities provided for men and women. Various systems have been designed to provide privacy. These are shown in Figure 7, together with those for separating the sexes. It should be noted that latrine doors should preferably open inwards.

A latrine design, whether of the family or communal type, which does not permit easy cleaning will not be acceptable to most people. In this respect, smooth, hard-surface floors of concrete, cement, brick, or similar material are best because it is easy to flush them with water.

Sanitation Guidelines

Fig. 7. Latrine Designs Ensuring Privacy and Separation of the Sexes

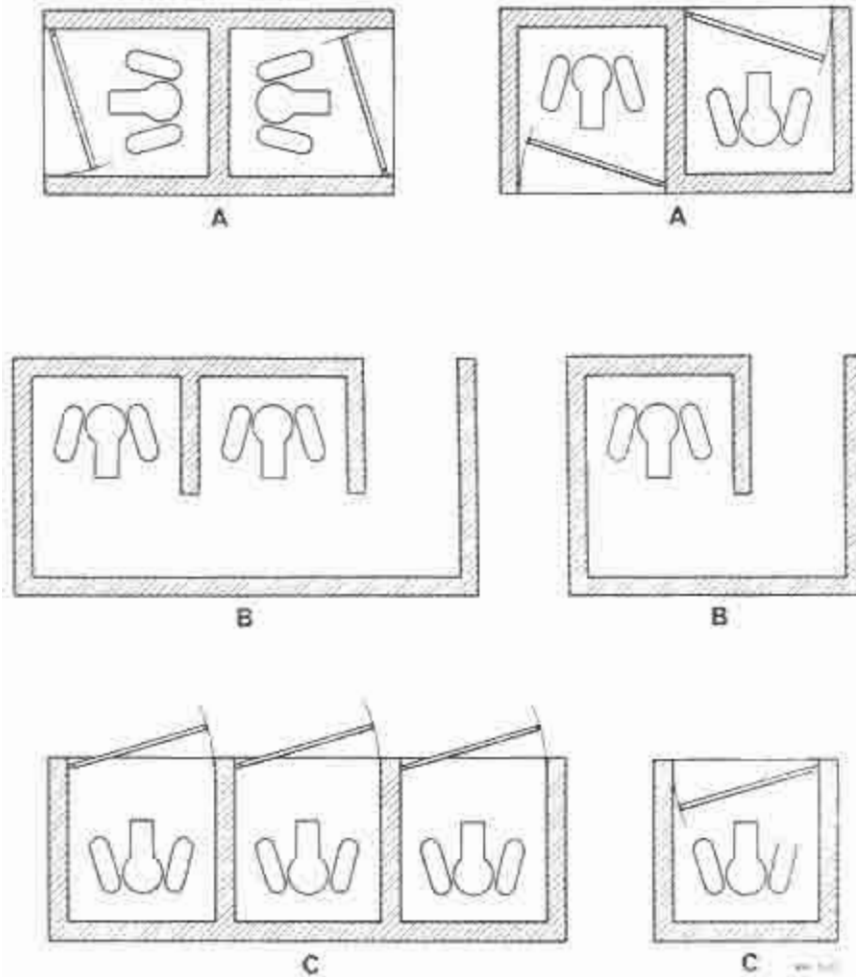

- A = These two layouts ensure complete separation of the sexes.
B = Semi-private installation. Small-type entrance. Defaecation may take place in corridor passage when latrine floor is dirty.
C = Preferred types, ensuring complete privacy.

Sanitation Guidelines

A latrine which is designed for too large a number of people is likely to get dirty quickly and remain so. This is likely to inhibit use of the latrine and may result in defaecation around the latrine building or in neighbouring bush. A one-hole latrine is adequate for a family of five or six persons. For communal latrines in camps, markets, and similar places, one hole should be provided for every 15 persons. In schools one hole should be provided for every 15 girls and one hole plus a urinal for every 25 boys.

(l) Soil conditions

Soil conditions are important for all sanitation technologies except those that can be completely built above ground level (i.e., vault latrines). Soil stability is important for VIP latrines, ROECs, aqua privies and pour-flush toilets. In unstable soils pits must be lined, often to their bases.

Soil permeability is also important for these technologies, as well as for septic tank soakaway trenches. In impermeable soils these technologies are inappropriate.

If the groundwater table is within 1 metre of the ground surface, VIP latrines, ROECs, and pour-flush toilets are of doubtful feasibility and will contaminate groundwater. They may be feasible if the soil is sufficiently permeable so that the liquid level in the pit will never be less than 0.5 meter below ground level. However, the pit may be unstable unless supported to its base, and mosquito breeding is likely to be a problem except in pour-flush toilets. Under these conditions the toilet slab may need to be raised above ground level. For ROECs and single-pit VIPs, which require large pits, pit excavation and lining are likely to be hazardous and very difficult.

The presence of rock near the ground surface creates difficulties for all technologies affected by soil conditions. VIP latrines, ROECs, and pour-flush toilets become considerably more expensive, but the temptation to build single pits with an effective life of less than 2 years should be resisted. Where possible assistance with mechanical diggers may facilitate the digging of the pits. Alternatively, shallow alternating pit latrines or raised pit latrines may be considered.

(i) Soil permeability

It is often useful to know the basic soil type of an area before starting to dig a well or latrine. Figure 8 gives a simple guide for the rapid identification of the main soil types.

Fig. 8. IDENTIFICATION OF SOIL

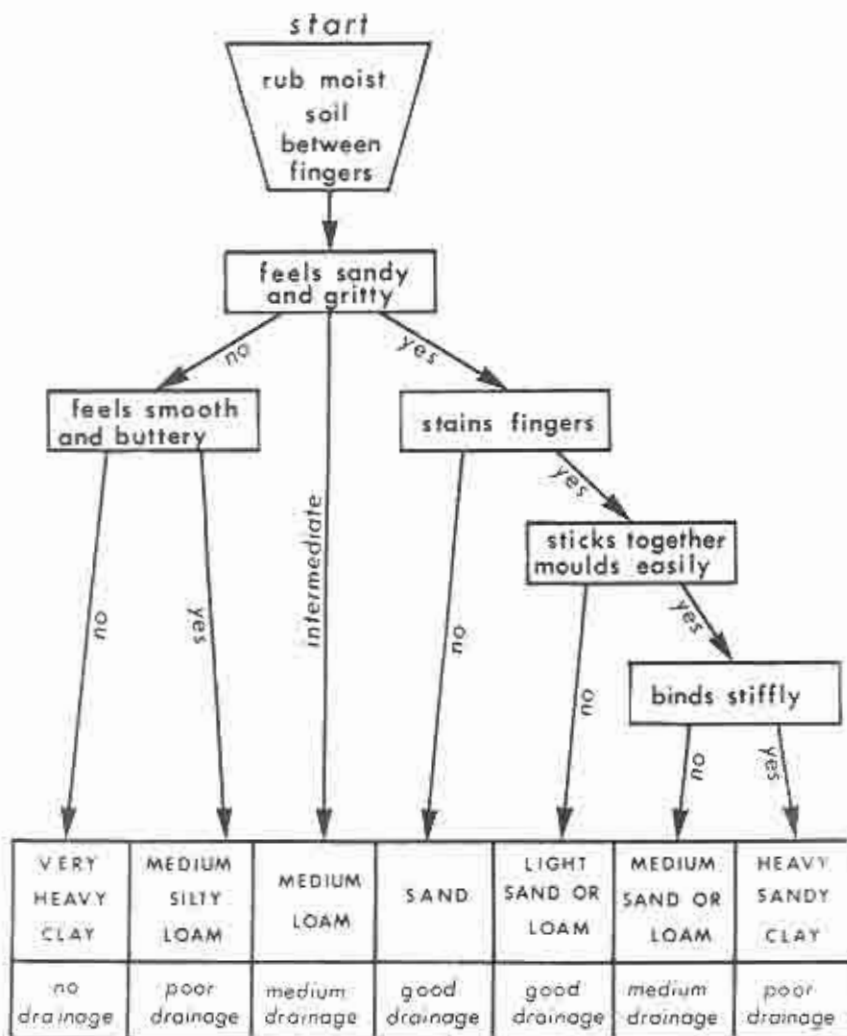

Sanitation Guidelines

The total amount of liquid entering dry latrine pits is normally low, so soils of lower permeability than would be considered for the disposal of septic tank effluent are still suitable for pit latrines.

Soils with very low permeabilities such as clays and silty clays are unsuitable for pit latrines as the liquid fraction of the excreta is unable to infiltrate the soil. This would necessitate frequent emptying of the pit, which may lead to unnecessary health hazards, if not carried out properly.

(ii) Soil stability

For the purpose of pit design, soils are either stable or unstable. Stability is defined as resistance to collapse and should be properly assessed. A simple, but rough test, runs as follows:

Soil samples are taken by hand-auguring. One sample should be taken every 50 cm to a depth of 3 m. Each sample is then hand-rolled to form a rough cylinder of approximately 2 cm diameter and 5 cm length. After sun-drying for two days or, preferably, oven-drying for two hours at 100 C⁰, the sample is gently crushed between one's thumb and fingers. Unstable (cohesionless) soils crush easily, whereas stable (cohesive) soils do not. This test requires some experience, and it is therefore a good idea to practise the test on soils of known particle size distribution and undrained shear strength.

Local knowledge of pit latrines is useful: if pit collapses due to soil failure have occurred, the soil should be considered unstable and pits should be lined.

(m) Construction of facilities

Besides the design of sanitation facilities, the middle-level sanitation technician may sometimes face problems relating to the construction of the selected technology. For instance, the construction of latrines or seepage pits in areas where rock or groundwater is encountered near the ground surface may pose problems which have no obvious or simple solution.

The sanitation technician should be aware of the nature of construction problems, in order to identify them and refer to the proper specialist. S/he must also

have some understanding of how to solve these problems. Some suggestions regarding construction features are included in the sections describing each technology option. These suggestions are, so far as is possible, oriented to the facility under consideration.

2.1.2. Pit Latrine and Ventilated Improved Pit Latrine (VIP)

(a) Description

These two types of latrines are discussed together, as they appear similar except for a vent pipe to reduce odours from the decomposing excreta.

The Pit Latrine, as shown in Figures 9 and 10, consists of a hand-dug hole in the ground covered with either a squatting plate or a slab provided with riser and seat. A superstructure is then built around it.

The Ventilated Improved Pit (VIP) latrine, shown in Figure 11, differs from the pit privy in that it has a tall vertical vent pipe with a flyscreen fitted at its top. There are two basic types of VIP latrine: the single pit latrine, and one with two pits known as the alternating VIP latrine or Ventilated Improved Double Pit Latrine (VIDP), shown in Figure 12. The VIDP is designed for the removal of the pit contents at regular intervals of two to three years. It is a permanent sanitation facility which is especially useful in medium-density housing areas, both rural and urban.

(b) Components and their design

The pit latrine has five main components: the pit; the base or foundation; the floor or slab; the mound, and the superstructure or shelter. The VIP has the same components, plus the vent pipe.

The pit

The function of the pit is to isolate and store human excreta in such a way that no harmful pathogens may escape. Provided that the soil is sufficiently permeable, urine and the liquid part of excreta seep into the ground through the walls and floor of the pit. The presence of solid rock or very hard soil near the ground surface generally prevents the construction of these latrines. Elevated pits or shallow alternating twin-pit latrines, with the cover slab raised above ground level as necessary, are preferable in such circumstances.

Fig. 9. THE PIT LATRINE

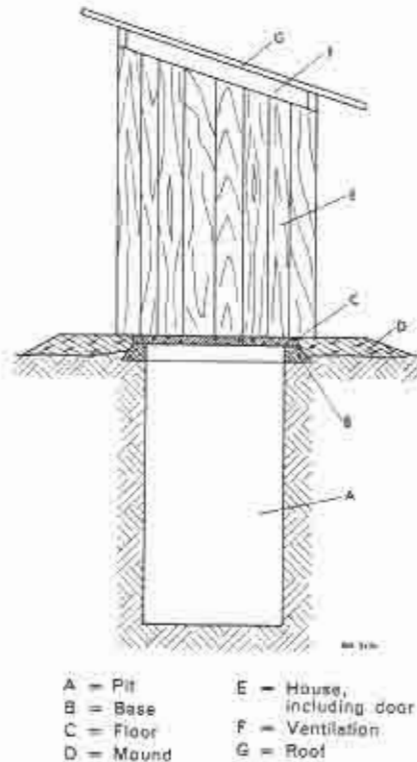

In general, a circular pit serving a single household (5-7 persons) requires a diameter of 1.0 to 1.5 metres. For square or rectangular pits a width of 1.0 to 1.5 m is recommended, although they are generally less stable.

In deciding on the volume of a pit, it is necessary to consider whether the pit will be wet or dry, i.e. whether it will penetrate the groundwater table or not. Wet pits have the advantage over dry pits in that they last longer, as their rate of solids accumulation is lower. However, wet pits can pose problems of mosquito breeding and of groundwater pollution. This is generally inadvisable and presents a major health hazard in areas where groundwater is used as a source of drinking water. If groundwater is never used for drinking purposes, then pollution of groundwater by latrines may be of little sanitary or health significance.

Fig. 10. TWO TYPES OF PIT LATRINE

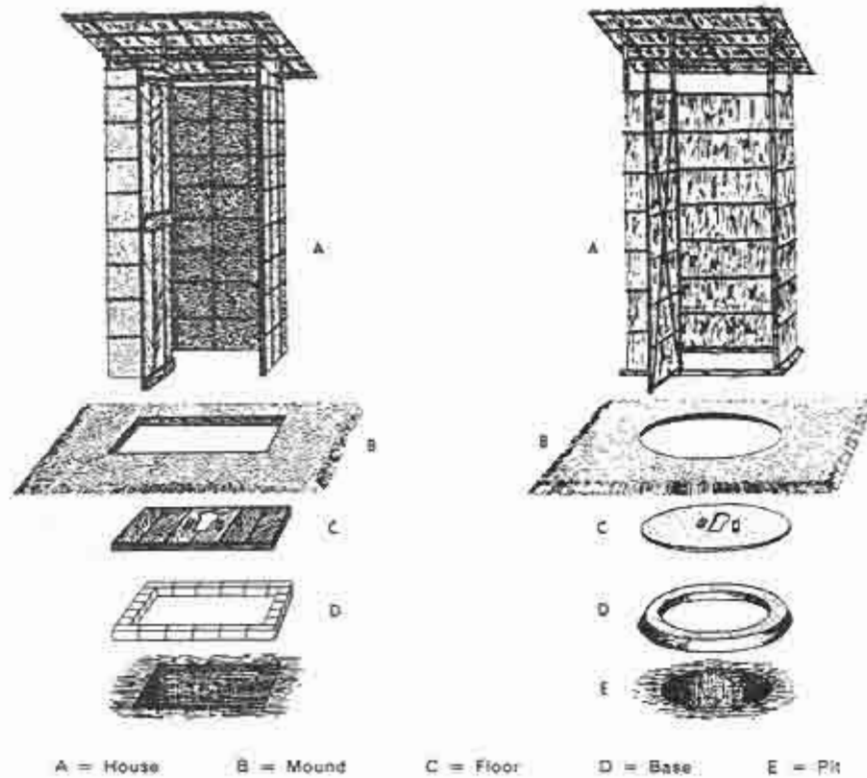

The required volume depends on the rate of solids accumulation, the number of users and the desired life of the pit. For design purposes, the rate of solids accumulation may be taken as 0.04 cubic metres per person per year in wet pits, and 0.06 cubic metres per person per year in dry pits. These design values should be increased by 50 per cent if bulky anal cleansing materials (e.g. corn cobs, cement bags, mud balls) are used, as these either degrade very slowly or not at all.

Fig. 11. THE VENTILATED IMPROVED PIT LATRINE

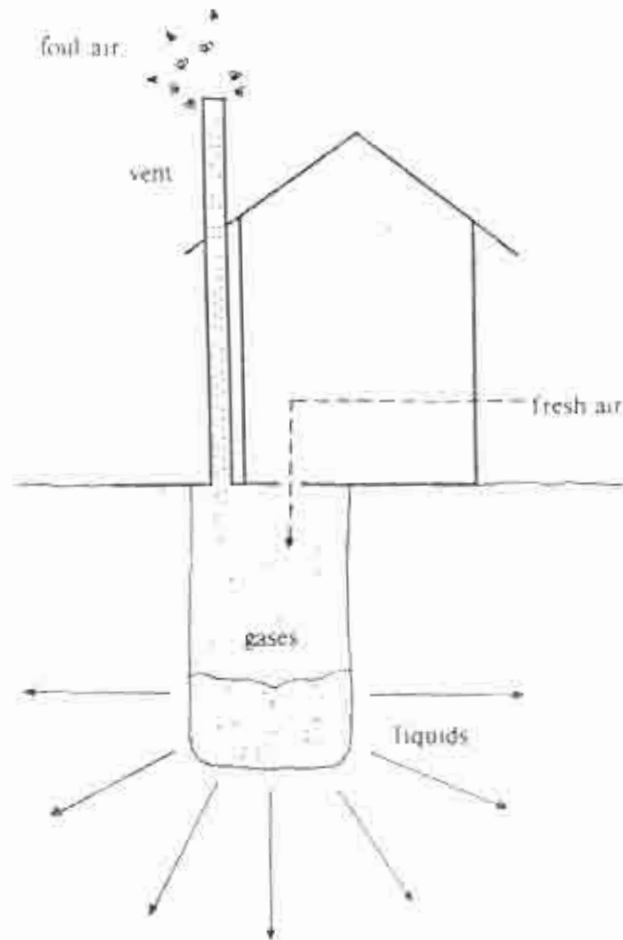

Sanitation Guidelines

The design life should be as long as possible; 10-15 years is considered desirable. The longer the design life, the longer the interval between relocating or emptying the latrine. For a circular dry pit with an effective depth of 2.5 m (i.e. with a total depth of 3 m) and a rate of solids accumulation of 0.06 cubic metres per person per year serving a family of six, the pit life for various diameters is given in Table 1:

Table 1 Effective Life of Dry Pit Latrines Three Metres Deep (i.e., with an effective depth of 2.5 m) Serving a Family of Six

| Diameter (m) | Area (m ²) | Effective Volume (m ³) | Effective Life (years) | Total pit volume below slab (m ³) |
|-----------------|---------------------------|--|------------------------------|---|
| 1.00 | 0.79 | 1.98 | 5.5 | 2.37 |
| 1.20 | 1.14 | 2.85 | 7.9 | 3.42 |
| 1.50 | 1.77 | 4.42 | 12.3 | 5.31 |

Footnote: solids accumulation is assumed to be 0.06 cubic metres per person per year.

The pit must not be allowed to fill up completely (right up to the underside of the cover slab). A free space of about 0.50 metres should remain empty. When the level of excreta reaches to within 0.5 metres of the underside of the floorslab the pit should be closed and filled with earth.

A new pit should be dug and the superstructure moved over it or rebuilt. The faeces in the old pit should be left to decompose for at least 12 months, after which the digested material may be removed and utilized as soil fertilizer or otherwise disposed of. The cleaned pit may then be reused. It may be necessary to provide support to prevent the pit walls from caving in. This is particularly important where latrines are dug in fine-grained alluvial, sandy soils, and similar formations (especially during the rainy season), or when they penetrate deeply into groundwater. Local experience with pit latrines is useful: if pit collapses due to soil failure have occurred, the soil should be considered unstable and the pit needs to be lined. Even in stable soil formations, it is desirable to line the top 0.5 metres of the pit, or to consol-

Sanitation Guidelines

idate this portion of the pit by plastering the soil face with a 1 cm thick coating of cement mortar (1 part cement, 5 parts sand).

Pits in unstable soils should be fully lined, otherwise there is the risk that the pit will collapse and the superstructure may fall into it. A variety of materials can be used to line the pit. Examples include concrete blocks, bricks, cement-stabilized soil blocks, masonry, stone rubble, perforated oil drums, rot-resistant timber and wire-mesh-supported geofabrics (Figures 13 and 14). Local availability normally determines which material to use. Where blocks, bricks, masonry or stones are used, the lining joints should be fully mortared in the top half metre (0.5 m) of the pit. Below this, the vertical joints should be left unmortared to allow the liquid fraction of the excreta to infiltrate into the soil. If the surrounding soil is very fine sand which would enter the pit through the open vertical joints, this should be prevented by placing a thin (approximately 100 mm) packing of fine gravel between the soil and the lining.

It is difficult to excavate and line pits in areas with a permanently high groundwater table. If petrol or diesel driven portable pumps are available, the groundwater can be removed and short lengths of concrete pipe inserted as excavation proceeds. This "mini-caisson" approach is the most satisfactory, provided the concrete pipes are made with sufficient holes to enable infiltration to occur. Perforated oil drums coated with bitumastic paint are an alternative, but corrosion is a problem in the long term.

The base or foundation

The base serves as a solid, impervious foundation upon which the floor (or slab) can rest. It also helps to prevent the escape of hookworm larvae which climb up the pit walls. Properly made of a hard, durable material, it helps to prevent the entrance of burrowing rodents and of surface water into the pit. The base should be high enough to raise the floor at least 10 to 15 cm above the level of the surrounding ground thus protecting the pit from flooding (see Figures 15 and 16).

Fig.13. VARIOUS COMBINATIONS OF DIFFERENT TYPES OF PIT, PIT LINING, BASE AND FLOOR

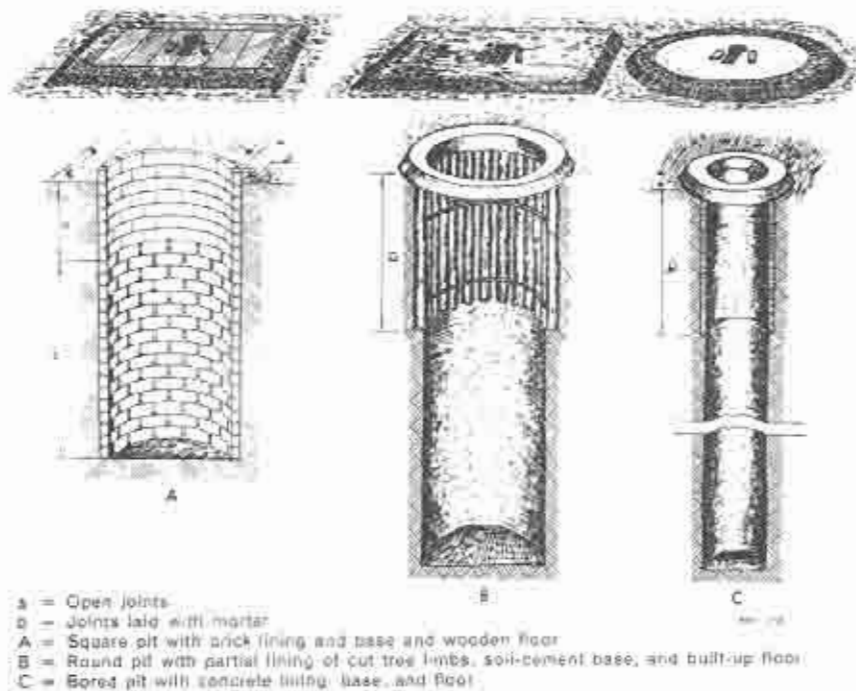

The following materials may be used to construct the base, depending upon local availability and cost:

- a) plain or reinforced pre-cast concrete - using same mix as for the floor;
- b) soil-cement - 5 to 6 per cent cement mixed with sandy clay soil and tamped at optimum moisture content;

Sanitation Guidelines

- c) clay - tight clay, well tamped at optimum moisture content;
- d) brick - mud dried, burned, adobe, etc.
- e) rough-cut logs - hardwood, termite-resistant.

Fig. 14. LARGE VOLUME PITS WITH SMALL FLOORS AND SUPERSTRUCTURES

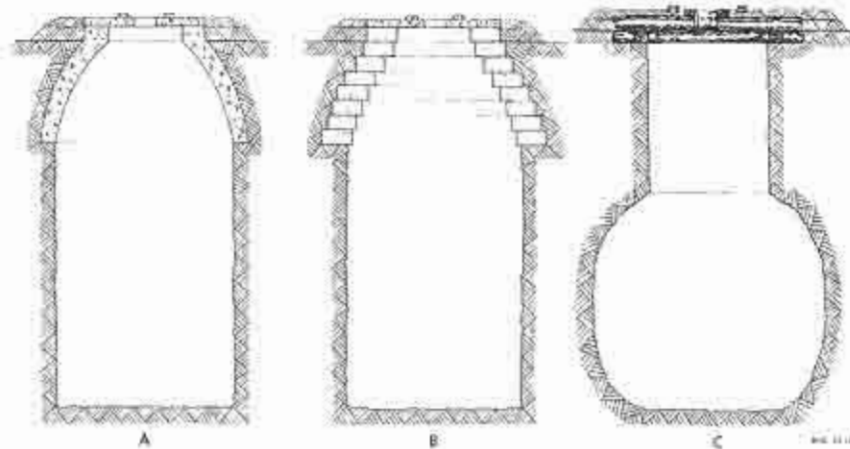

- A = Large diameter or square pit with soil-cement cone at top to reduce size of opening and accommodate small floor (Cone may be of any material which will provide the strength to support the weight on top.)
- B = Similar to A, but with brick
- C = Pit showing enlarged lower portion to provide increased volume; practicable only in very stable soil

Fig. 15. CEMENT BASE

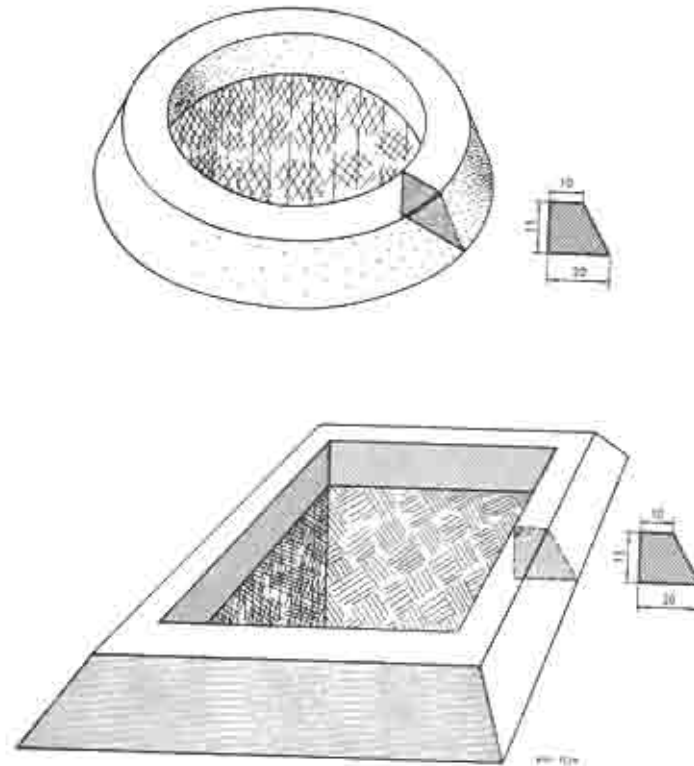

Measurements shown are in centimetres

The floor slab

The floor supports the user and covers the pit. It should be constructed so as to fit tightly and be flush with the outer edge of the base. It may be made from reinforced concrete, from rot-resistant timber which is covered with soil and then mortared, or from fibreglass-reinforced plastic if such material is available (see Figure 17). Concrete floors are generally considered to be the most practical, most acceptable, and economic. The next most suitable are wooden floors. "Built-up" floors, as shown in Figures 18 and 19, are less desirable because they are difficult to keep clean and, as they are easily soiled, are more likely to spread hookworm.

Fig. 16. LOG BASE

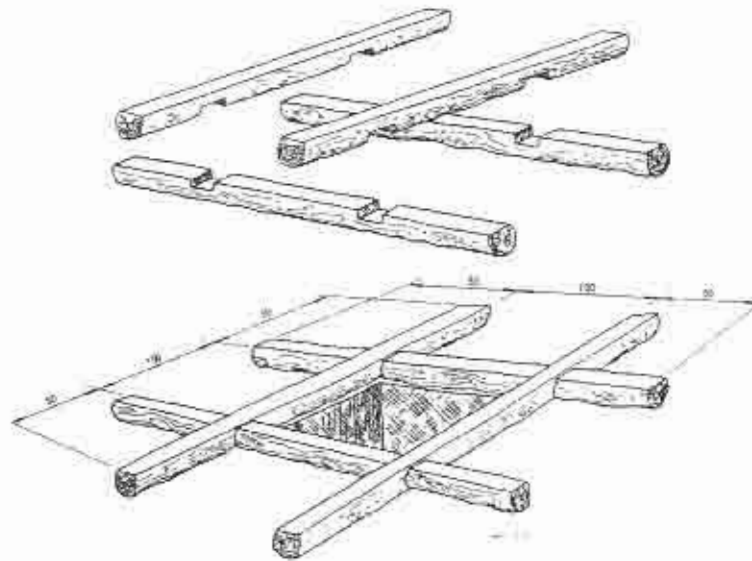

Measurements shown are in centimetres

The squat-type latrine slab is the most suitable for rural areas of the Eastern Mediterranean Region, although in some areas a slab provided with a riser and seat may be preferred. Slab design requires careful investigation. The customary posture of defaecation has an important bearing on the acceptance or rejection of latrines. In squatting plates, the hole should be of a size and shape that will minimise accidental soiling of the floor. An opening of approximately 40 cm length will satisfy this requirement. The hole should not be so large that small children may fall into the pit. An opening not exceeding 18 cm in width or diameter will meet this requirement (see Figure 20). A keyhole shape is suitable.

Sanitation Guidelines

Fig. 17. FLOOR SLAB CONSTRUCTION

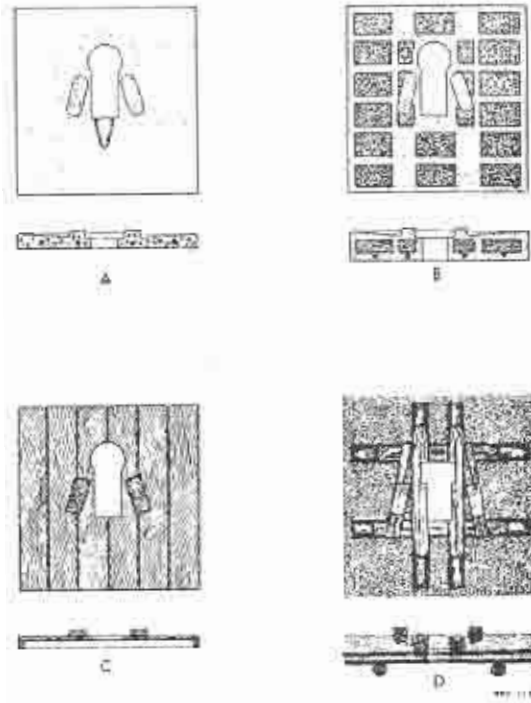

- A = Reinforced concrete
- B = Reinforced brick-mortar
- C = Wood
- D = Floor built up with tree limbs and earth

Sanitation Guidelines

Fig. 18. BUILT UP WOODEN BASE

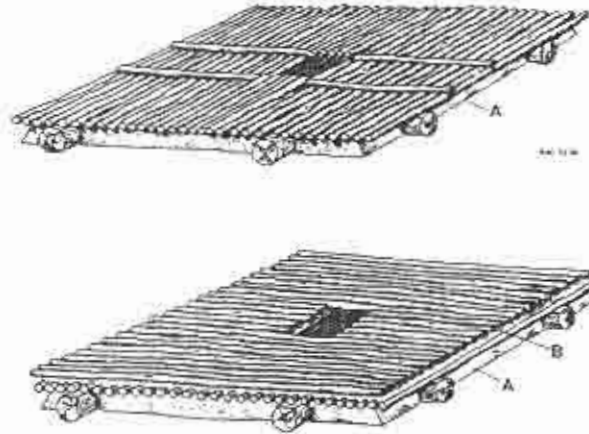

- A = Fill in with compact earth all around after the base is placed and before covering with tree limbs
- B = First layer of limbs is covered with 5 cm (2 in.) of dense earth, followed by another layer of tree limbs

Fig. 19. BUILT UP EARTH BASE

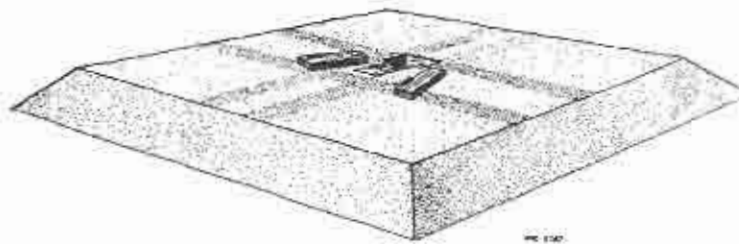
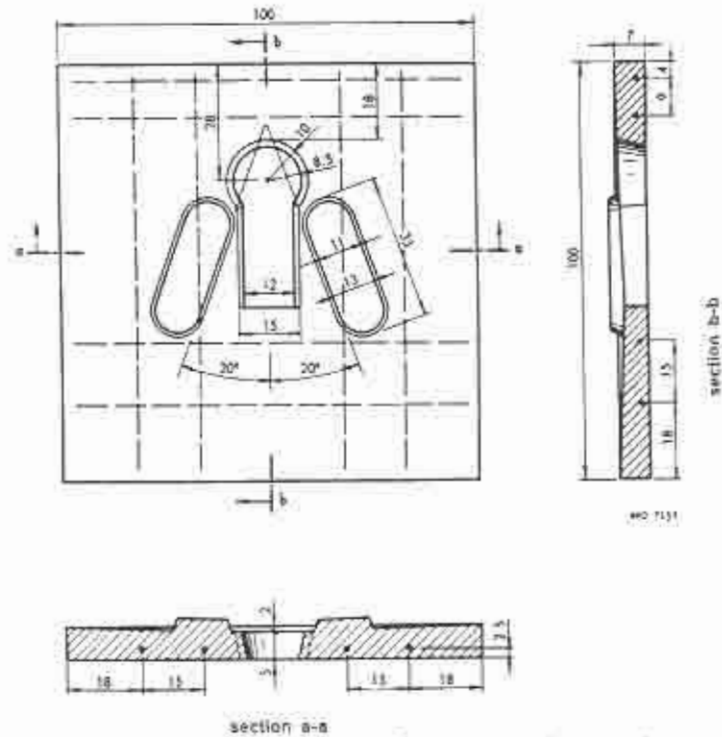

Fig. 20. SQUARE CONCRETE SLAB FOR PIT AND BOREHOLE LATRINE



Measurements shown are in centimetres

Squatting slabs should be provided with slanting foot-rests to minimize the possibility of soiling the floor. Foot-rests usually form an integral part of the squatting plate. They should be designed for use by adults and children and be easy to clean (see Figure 20).

The distance between the rear edge of the opening and the superstructure wall should be between 10 cm. and 18 cm.. This should prevent the user's back touching the wall which may not always be clean and free from ants and other insects.

Sanitation Guidelines

Where the preferred posture is squatting, it is important that the surface of the cover slab be very smooth and that it slopes towards the squat hole in order to provide easy drainage for urine and water used to clean the floor. The recommended slope is 5 per cent.

In VIP latrines the cover slab has two holes. Besides the squat-hole, another hole, circular or square depending on the design of the ventilator, must be provided.

The mound

The function of the mound is to protect the pit and base from surface run-off which otherwise might enter and destroy the pit. It should be built up to the level of the floor and be very well tamped (see Figure 9). It should extend at least 50 cm (20in.) beyond the base on all sides. The mound may be built up considerably above the ground for protection against tides and flood waters. It will normally be built with the earth excavated from the pit or surrounding area, and may be consolidated with a stone facing to prevent it from being washed away by heavy rains. In front of the entrance door, it may be preferable to supplement the mound with a masonry or brick-built step. This helps to keep the latrine floor clean.

The superstructure

The superstructure affords privacy and protects the user and the installation from the weather. Figures 21,22,23,24 and 25 show various types of shelter and a typical wooden superstructure frame for use in rural areas. From a sanitary point of view, the superstructure is less important than the pit or the floor. Given limited advice from the sanitation technician, the superstructure may be left to the users themselves to construct. They can choose to build the superstructure from a variety of locally- available construction materials, using available skills and preferred architectural styles. In this way, social preferences are respected, the householder is more likely to know how to repair the superstructure should it become damaged, and should be able to move it when this becomes necessary.

Fig. 21. COMPLETED LATRINE, SHOWING PALM THATCH WALL AND ROOF COVERING



Fig. 22. WATTLE SUPERSTRUCTURE WITH PALM THATCH ROOF



Fig. 23. SUPERSTRUCTURE OF CUT LUMBER WITH CORRUGATED METAL OR FIBRE CEMENT ROOF



A properly-built superstructure should conform to certain rules, the most significant of which are:

1. Size. Ideally, it should fit the dimensions of the floor or slab and should never be too large as this may encourage users to defaecate on any part of the floor. At the door, the distance of the roof from the slab near the entrance door should be 2 m or more.
2. Ventilation of superstructure. Openings of 10-15 cm width should be provided at the top of the superstructure walls to provide ventilation.

Sanitation Guidelines

3. Lighting. Natural light should be available wherever possible. However, the superstructure should provide sufficient shade over an uncovered seat or hole in order not to attract flies.
4. The roof should cover the house completely and have a large overhang to protect the mound and the walls from rain or roof drainage.

**Fig. 24. TYPE OF SUPERSTRUCTURE RECOMMENDED
BY US PUBLIC HEALTH SERVICE**



A = Vent pipe with lateral outlet

Fig. 25. SUPERSTRUCTURE OF BRICK WITH TILE ROOF



Vent Pipe Design for VIP Latrines

Vent pipes have been successfully constructed from a variety of materials. These include fibre cement, polyvinyl chloride (PVC), unplasticized PVC, bricks, blockwork, cement-rendered reeds, and cement-rendered hessian supported on steel mesh. Large diameter bamboo with the cell dividers removed can also be used. Important factors to consider when selecting vent pipe material include durability (including corrosion resistance), availability, cost and ease of construction. Thus, for example, ventpipes made from thin galvanized steel are not recommended as they corrode rapidly. PVC pipes become brittle when exposed to high sunlight intensities.

and it is therefore better to use PVC pipe made with a special stabilizer to prevent damage by ultraviolet radiation. However, this grade of PVC may not be generally available.

The vent pipe should be sufficiently long so that the roof does not interfere with the flow of wind across the top of the vent pipe. With flat roofs, the top of the vent pipe should be at least 0.5 metres above the roof, and in the case of sloping roofs the vent pipe should also be 0.5 metres above the highest point of the roof. Current recommendations for the minimum internal size of vent pipes are:

Fibre Cement or PVC 150 mm diameter
Brick 230 mm square
Cement-rendered reed or hessian 230 mm diameter

In exposed locations where wind speeds are greater than 3 meters per second, the minimum diameter of fibre cement and PVC pipes may be reduced to 100 mm, and to 200 mm in the case of cement-rendered reed or hessian.

The latrine should be located at least 2 metres away from overhanging tree branches and anything else that might impede the flow of wind across the top of the vent pipe. The vent pipe and any openings (doorways, windows, gaps between the roof and walls) should be located on the windward side of the superstructure. If, however, it is impossible to have both vent pipe and openings on the windward side, at least one of them must be and this should preferably be the openings. It is extremely important to avoid openings on opposite sides of the shelter, as this would significantly reduce the pressure differences which contribute to the updraft in the vent pipes.

In general, the vent pipe should be located on the outside of the superstructure, since it is more difficult and expensive to ensure a rainproof and wind-tight seal between the roof and a vent pipe going through it. Moreover, in very sheltered areas, thermally-induced ventilation may be more important than that due to the wind, and thus the vent pipe must be placed outside the superstructure, on its sunny side and painted black. The vent pipe must be rigidly fixed to the superstructure and the cover slab. Design recommendations are given in Figure 26.

The purpose of the screen fixed at the top of the vent pipe is to prevent the passage of flies and mosquitoes. The mesh size must not exceed 1.2 mm x 1.5 mm. Finer mesh is not recommended as it will result in decreased ventilation rates. The flyscreen must be made of corrosion-resistant material that is able to withstand in-

Sanitation Guidelines

tense rainfall, high temperatures, strong sunlight and corrosive gases. Inexpensive PVC-coated glassfibre screens have been extensively used but after about five years they become very brittle and susceptible to damage by birds and lizards. It is preferable to use stainless steel screens which last indefinitely. Even though they are more expensive the cost is small in comparison with the total cost of the latrine.

It is important to ensure that the flyscreen is tightly fixed to the top of the vent pipe in order to prevent access by insects. Design details are shown in Figure 27. When the flyscreen is in place there should be no obstruction to the wind flow across the top of the vent pipe.

Alternating Twin-pit Latrines

Alternating twin-pit latrines (see Figure 12) have two separate pits, each with their own vent pipe, but only one superstructure. The cover slab within the superstructure has two squat-holes, one over each pit. Only one squat-hole and pit are used at a time. After one to three years, when this pit is full, its squat-hole is covered up and the second pit put into service. After a further period of one to three years, when the second pit is full, the contents of the first pit are removed to enable it to be used again. This alternating cycle is repeated indefinitely. This type of latrine is a permanent sanitation facility, especially suitable for use in urban areas, and in small communities with high housing density, where there is insufficient space on each housing plot for two or more single-pit latrines. Many of the design details for alternating twin-pit latrines are the same as for single-pit latrines; specific differences are as follows:

1. Pit function and design

The function of the pit is to store excreta until they can be safely removed. With the exception of human roundworm ova, *Ascaris lumbricoides*, all excreta pathogens die within 12 months at temperatures above 20°C. In most developing country climates, one year is therefore the minimum storage requirement for each pit. Usually, to provide some degree of flexibility in the design of latrine emptying schedules (especially to allow for breakdown of any mechanical equipment and for seasonal problems of access), a minimum period of two years is specified.

Fig. 26. METHODS OF FIXING VENT PIPES TO VENTILATED LATRINES

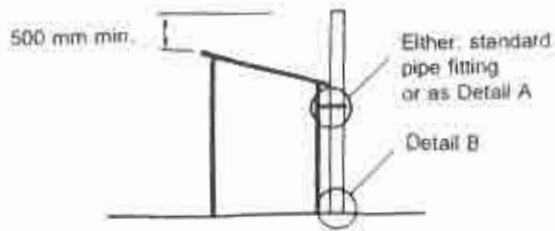

General arrangement

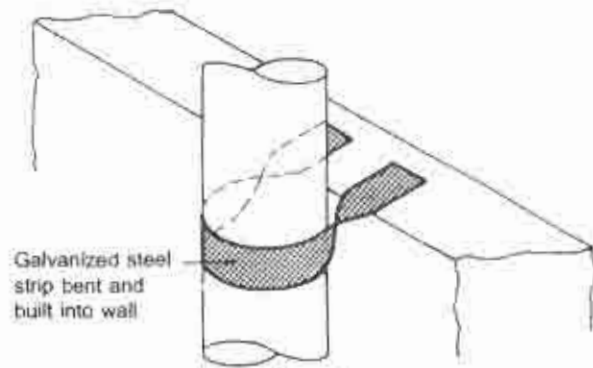

Detail A

Method of fixing pipe to superstructure

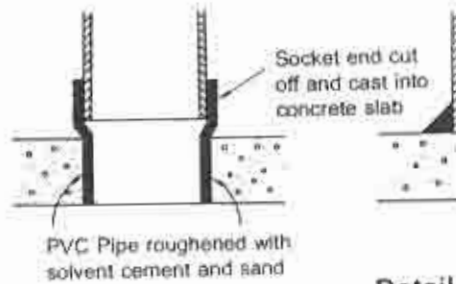

Detail B

Alternative methods of fixing vent pipe to slab

Fig. 27. METHOD OF FIXING FLY SCREEN TO A VENT PIPE

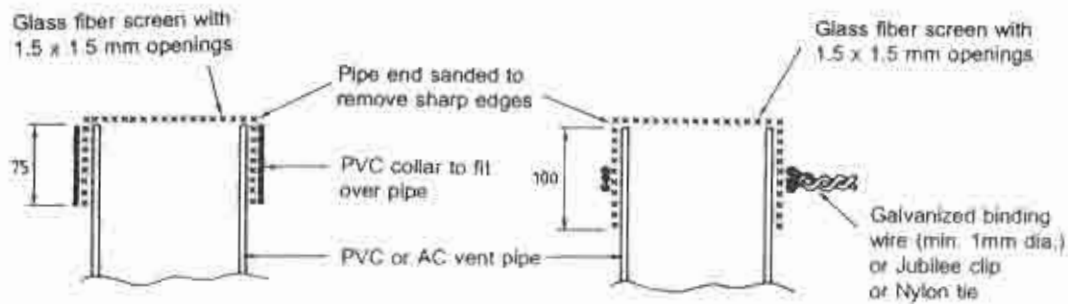

Alternative methods of fixing fly screen to AC and PVC vent pipes

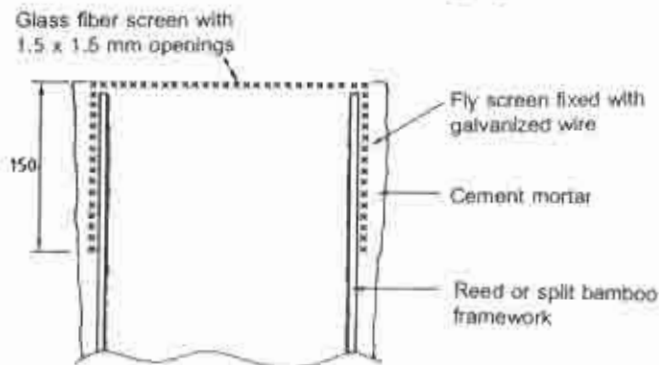

Measurements shown are in millimetres.

Method of fixing fly screen to a 'rural' vent pipe

Sanitation Guidelines

Calculation of the necessary pit volume shows that in most cases the pits are quite small; for example, for a family of 10, each pit should have an effective volume of only 1.2 cubic metres, assuming a solids accumulation rate of 0.06 cubic metres per person per year only and a two-year storage time. Consequently, pits can be much shallower (often less than 1 metre total depth) than for single-pit latrines. This may be a significant advantage if either groundwater or hard rock is close to the surface of the ground.

The pit shape is normally rectangular and the pit may extend either to each side of the superstructure or to its rear (see Figure 28). The pits are lined as necessary. Suitable locally-available material (such as brick, concrete or cement-stabilized soil blocks) is used to build up the partition wall between the two pits. This partition wall must have a good foundation and be fully mortared to prevent any cross-flows of air between the pits. This would interfere with the ventilation and might cause odours to enter the superstructure. For the same reason, the cover slab must be firmly bedded with mortar on the partition wall, as well as on the brick or blockwork collar.

2. Cover slab design

The cover slab is usually made in reinforced concrete in three or more sections (Figure 29): a central section with two squat-holes and holes for the two vent pipes, and at least two removable covers (one for each pit) to allow access for emptying. The edge details of the cover slab sections shown in figure 29 are important as there must not be any gaps between the central and outer sections which permit the escape of either flies or odours. A lime mortar or a weak cement mortar should be used to bed the removable slab sections to the central section and to the collar. As with single-pit latrines, the cover slab should be sloped towards each squat-hole.

3. Superstructure and vent pipe design

The superstructure and vent pipe design details are similar to those for single-pit latrines. Alternating twin-pit latrines have been installed inside houses, with the pits accessible from outside; in some cultures such an arrangement may be socially preferable to external superstructures.

4. Emptying of pits

Manual removal of the humus-like material in the pits, which should not be handled until it is at least one year old, should present little or no health risk as all the excreted pathogens are non-viable, except for a few *Ascaris* ova. Discussions

Sanitation Guidelines

with the intended beneficiaries (or their leaders) prior to the installation of alternating twin-pit latrines may indicate that they consider the handling of the pit contents to be a socially-unacceptable task. Mechanical emptying can be planned a long time ahead, while the emptying of a single pit latrine is always an urgent matter. The pit contents may then be used to fertilize agricultural land or disposed of in sanitary landfills.

Fig. 28. ALTERNATIVE PIT GEOMETRIES FOR ALTERNATING TWIN-PIT VIP LATRINES

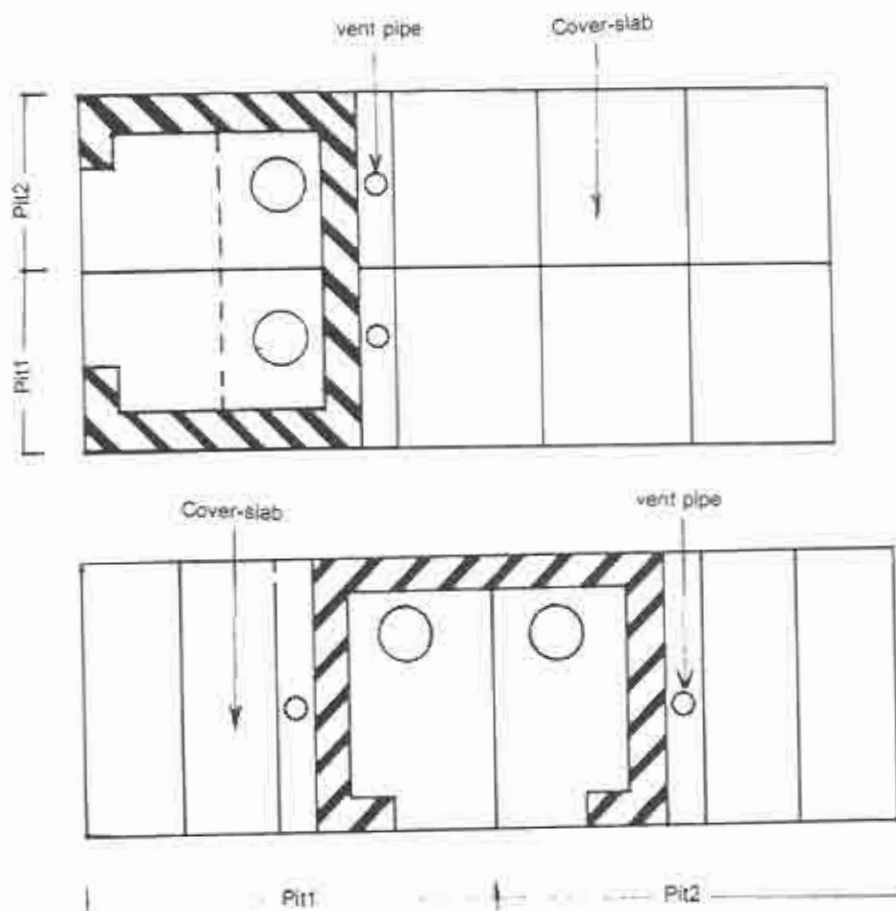

Operation and Maintenance

When pit or VIP latrines become full, i.e. the level of excreta reaches to within 50 cm of the cover slab, there are two options available to their owners: the construction of a new latrine on an adjacent site, or emptying the existing latrine.

In rural areas and in small communities with low housing density, construction of a new latrine is generally the preferred solution, as space for the new latrine is usually available. As much as possible from the old latrine (for example, the cover slab and vent pipe) should be reused.

Manual emptying poses health risks due to the excreted pathogens that may be present in the fresh fecal material at the top of the pit. In addition, this is often not a socially acceptable task. Mechanical emptying is rarely feasible in rural areas. In urban areas manual emptying has the same disadvantages, but mechanical emptying might be feasible, especially if the pit were wet, as the procedure is essentially similar to desludging septic tanks. However, the solids at the bottom of deep pits will often be highly compacted and difficult to remove by the standard vacuum equipment used to desludge septic tanks. Dry pits are considerably more difficult to desludge mechanically than wet pits. Air drag mechanical systems are the only currently-available option for emptying such pits. When a latrine which is to be mechanically emptied is built in the backyard of a house or compound, space must be left free around the superstructure for the desludging truck or equipment to reach the pit easily. A width of 2.75 to 3.00 metres is recommended for this purpose.

Pit latrines and VIP latrines require a minimum level of day-to-day operation and maintenance.

- 1) The most important aspect is cleanliness. A latrine which is dirty and soiled with excreta and in a constant state of disrepair will soon be abandoned. The slab and squat-hole must be flushed with water and kept clean at all times, and no poultry or animals should be housed in the superstructure. The superstructure should be kept clean, and vegetation immediately surrounding it should be trimmed.
- 2) Cracks in the slab or foundation and holes in the surrounding mound leading directly to the pit should be promptly sealed.

**Fig. 29. COVER SLAB DETAILS FOR ALTERNATING TWIN-PIT
VIP LATRINES**

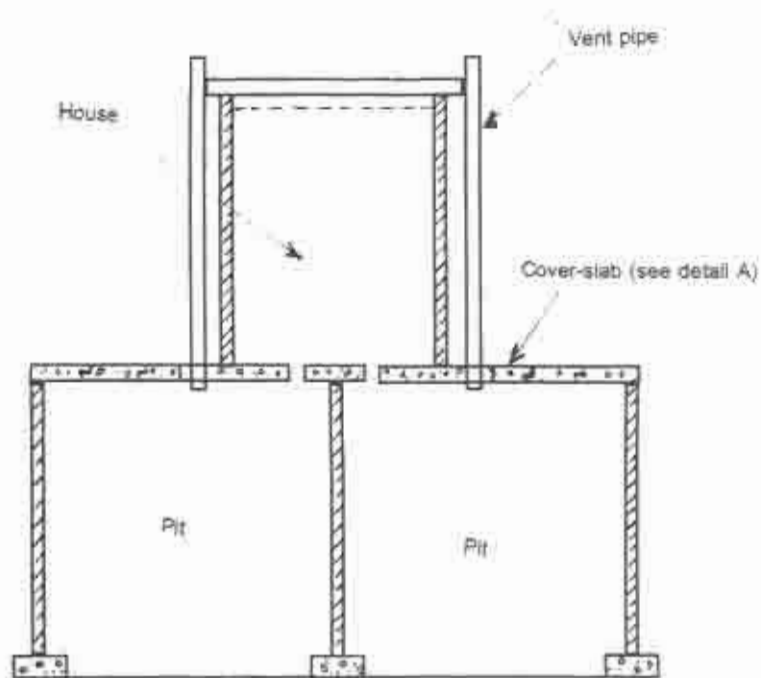

Detail A

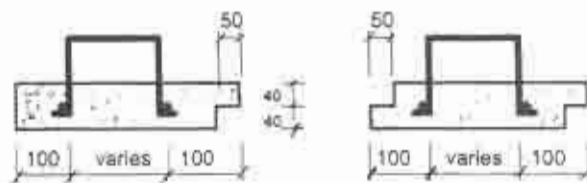

Measurements shown are in millimetres.

Sanitation Guidelines

- 3) In simple pit latrines the pit should be kept dark with a proper cover which prevents the entry of sun rays. This helps to prevent flies from entering the pit. The regular use of a hole cover should be encouraged in pit latrines, but **not** in VIP latrines.
- 4) In VIP latrines, it is important that the squat-hole or pedestal seat be kept open at all times, as covers interfere with the circulation of air which is essential for fly and odour control.
- 5) To prevent mosquito breeding in wet pits, it may be desirable to add a cupful of kerosene each week to the pit, or to spray it with an insecticide (e.g. Malariol, or similar product).
- 6) No disinfectant should be added to the pit.

Suggestions for Construction of a VIP Latrine

1. Select the best location for the pit and clear the area of vegetation. Mark out on the ground the dimensions of the pit using wooden stakes or pointed sticks, as shown in Figure 30. Mark the excavation for the chute if an offset pit is to be constructed.
2. Build the base around the pit site before digging the pit to prevent the top of the pit walls from crumbling and to ensure that the slab or cover can be put in place immediately after the pit is dug and lined. The corners of the base should normally be square.
 - 2(a) Wood Base: Cut four logs, poles or wood beams to the desired length. Cut two notches, as shown in Fig. 30(B), through each log, to fit together and form the base around the pit site. Bind the logs with heavy cord or twine or nail them together.
 - 2(b) Concrete Block or Brick Base: Lay a straight row of bricks or blocks along each side of the pit site as shown in Figure 30(C). The blocks should either be mortared together or fit tightly. Tamp the blocks in place or scrape away dirt to ensure that the rows or blocks are level. If the blocks or bricks are mortared together, cover them with damp straw, leaves, or grass and allow a few days for the mortar to set.

Sanitation Guidelines

Fig. 30. PIT LATRINE (a) LOCATION OF PIT SITES
(b) WOOD BASE (c) BLOCK OR BRICK BASE

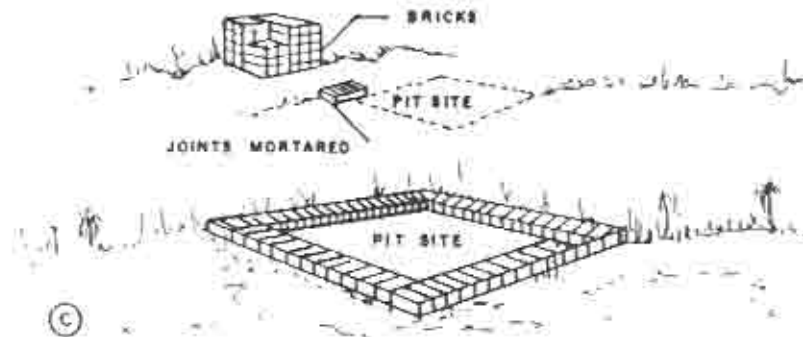
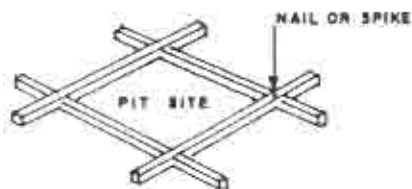
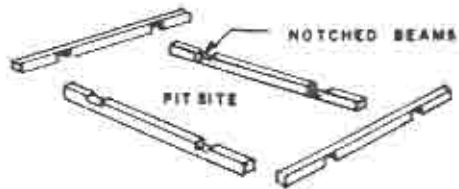

Sanitation Guidelines

2(c) **Poured Concrete Base:** Dig a shallow level trench 150 mm wide and 100 mm deep around the pit site. The width and depth of this trench determine the width and thickness of the base. The trench lines should be straight, the bottom tamped, and the sides and bottom clean and free of loose dirt. Mix concrete in the proportions (by volume): one part cement, two parts sand, four parts broken stone (not over 2 cm in diameter) or gravel, and just enough water to produce a stiff but workable mixture. The sand and gravel should be free from dirt and other material. Fill the trench with the concrete mix, cover with damp straw, leaves, or grass and allow a few days for the concrete to set thoroughly.

3. Dig the pit after the base has been constructed making the sides smooth and vertical. Use a plumb line (string tied to rock or weight) to check the sides during the excavation.

4. Support the sides of the pit to prevent caving when excavating deeper than 2 m. Secure the sides with logs, poles, boards, bamboo or other local shoring material when the depth reaches about 2 m. Continue digging, leaving a 75 to 100 mm step or ledge around the walls to support the shoring material. Shore up the lower walls when the pit reaches the correct depth. Do not hand dig a pit deeper than about 3.5m.

5. Measure the depth and make the pit floor fairly level when the correct depth has been reached.

6. If required, install the lining after the pit is fully excavated. The lining should extend from the bottom of the pit to the base. If the pit has been shored, the shoring material can be left in place and serve as the lining.

6(a) **Log, Pole or Bamboo Lining :** Cut logs or poles to a length equal to the depth of the pit. Place the logs or poles vertically along the sides of the pit. The poles should reach from the bottom of the pit to the base and should be placed 25 to 75 mm apart. Cut four cross poles equal to the length of the pit, and four cross poles equal to the width. Nail or tie the cross poles in place about 0.5 m from the top and bottom of the pit walls to secure the vertical poles.

6(b) **Wood or Board Lining:** Cut boards in lengths equal to the length and width of the pit. Cut four long boards or posts to a length equal to the depth of the pit. Put a long board or post in each corner of the pit and place the shorter side boards horizontally along the pit walls and nail them to the corner posts. The side boards should be spaced about 25 to 75 mm apart.

Sanitation Guidelines

6(c) Concrete Block or Brick Lining: Build the blocks or brick up the walls of the pit leaving 75 mm open spaces between the bricks. Do not use mortar except for the top two courses of blocks or bricks in order to provide additional strength.

7. The slab may be cast in wooden formwork on a layer of sand spread over the ground. Reinforcement may be made of hog-wire or of 6mm diameter reinforcing steel. Concrete should be carefully poured in the form and should be well tamped or spaded as this will make it flow well around the reinforcing bar. After about 6 to 8 hours the surface of the slab should be trowelled with a steel trowel to produce a smooth finish to the concrete. The fresh concrete should be covered with a damp mat or straw, which should be sprinkled with water and kept constantly in a moist condition for seven days.

8. Set the slab or cover in place over the pit. The size of the slab should be such that it has a minimum bearing of 80 mm (preferably, 100mm) on the base wall on all sides. If the slab or cover is in sections, use tar or other materials to seal all joints.

9. Waterproof around the edges of the slab or cover where the slab rests on the base. Do not mortar the slab or cover to the base when the slab or cover is designed to be removed for emptying the pit.

10. Place an earth mound, well tamped or lined with flat stones or masonry, around the edges of the base and slab.

11. Build the shelter above the slab using local materials and construction style.

Cost

The cost of pit or VIP latrines will vary considerably from country to country and within countries. Cost will depend on the design, local costs of labour and materials, and the extent of community, or family, participation and self-help. In some countries, it has been recommended that the maximum cost of a household simple pit latrine, including all labour and materials, should not be more than the average monthly income of a manual labourer. While this may be a somewhat optimistic goal, it is extremely desirable that a latrine's cost should be reduced to the minimum consistent with the criteria of health protection, structural safety, and social acceptability.

Sanitation Guidelines

Advantages and Disadvantages

The VIP latrine satisfies most of the sanitary requirements cited earlier and can play a major role in the prevention of excreta-borne diseases in small communities. It has the advantage of significantly reducing odours and flies but the provision of the screened vent pipe adds to its cost and maintenance.

Simple pit latrines, however, have a number of disadvantages. They are probably the most widely used excreta disposal facility in the developing world. Although many traditional pit latrines are quite well constructed a large number require substantial improvement in order to become safer and more hygienic.

Due to a lack of technical knowledge many simple pit latrines are inadequately constructed on unstable ground with the result that many collapse after a relatively short time. This is not only dangerous to the user but represents a loss of investment. Floors are often constructed from wood which is sometimes covered with earth. Such surfaces are easily fouled and provide ideal breeding grounds for hookworm. Dampness and termites can erode the wooden floor causing its collapse into the pit.

The simple pit latrine presents both odour and fly problems. It concentrates excreta in a single location close to the home and, unless scrupulous cleaning and covering of the drop hole are ensured, the flies which invade the latrine are a serious health hazard.

Wherever possible the upgrading of simple pit latrines should be considered so that the floor slab is made as hygienic as possible and fly and odour problems are reduced.

With a minimum of attention to location and construction of simple pit and VIP latrines, there should be negligible soil pollution and no surface or groundwater contamination. Both the simple pit and the VIP latrines have simple designs and are easy to use and maintain. Their life span will vary from 5 to 15 years, depending upon the pit volume and the use and abuse to which they are put. Water is needed only for cleaning the slab. The chief advantage of simple pit and VIP latrines is that they can be built by the family with little or no outside help and from locally-available materials.

2.1.3. Reed's Odourless Earth Closet (ROEC)

Description

The significant difference between Reed's Odourless Earth Closet (ROEC) and the VIP latrine, is that in the former the pit is completely offset. Excreta is introduced into the pit of a ROEC via a chute, as shown in Figure 31. Usually the pit is longer than in other types of pit latrine.

Components and their Design

The Pit

The volume (V) of a pit of less than 4 metres depth may be calculated from the equation:

$$V = 1.33 C \times P \times N$$

where C = rate of solids accumulation, cubic metres per person per year;
P = number of people using the latrine;
N = number of years the pit is to be used before emptying, usually 15 to 20 years.

The rate of solids accumulation (C) of a dry pit should be 0.06 cubic metres per person per year. Where anal cleansing materials that are not readily decomposed (such as grass, leaves, maize, mud balls, cement bags, etc) are used, this figure should be increased by 50 percent. For wet pits, the rate of solids accumulation should be 0.04 cubic metres per person per year.

The factor 1.33 is introduced because the pit is either filled in with earth or emptied when it is three-quarters full. Where soil conditions permit, large diameter or cross-section pits may be constructed, although special care must be given to supporting the latrine base and superstructure. As an example, the pit volume of a household ROEC dug in dry soil and serving 10 people for 20 years would be $1.33 \times 0.06 \times 10 \times 20 = 15.960 \text{ m}^3$, say 16 m^3 . For a wet pit, the volume would be: $1.33 \times 0.04 \times 10 \times 20 = 10.640 \text{ m}^3$.

Sanitation Guidelines

The ROEC pit can be built with a floor which slopes away from the superstructure so as to facilitate redistribution of the excreta.

The ROEC pit offers the following advantages over those of pit and VIP latrines.

- (1) The pit is larger and thus has a longer life.
- (2) Since the pit is completely displaced, the users (particularly children) have no fear of falling into it.
- (3) It is not possible to see the excreta.
- (4) The pit can easily be emptied, so that the superstructure can be a permanent facility. The width of the pit is generally 1 metre and, for easy emptying, its depth should not exceed 3 metres.

The pit cover, located behind the superstructure, will consist of removable slabs whose joints are sealed with mortar or tar. A manhole with a heavy and tight fitting cover may also be provided.

The squatting plate

Along with the concrete squatting plate, a steep (60°) sloping chute is provided to direct the excreta into the adjacent offset pit, as shown in Figure 31. The chute diameter should be 20 cm., increasing under the squatting plate so as to attach around the entire squatting hole which, of course, is larger. The chute may be made of metal, polyvinyl chloride (PVC), or ferrocement. It is important that the chute be straight and smooth to facilitate cleaning.

Operation and Maintenance

The operation and maintenance of ROECs are the same as for other latrines. The only difference is the additional care which must be given to keeping the chute pipe clean at all times. For this purpose a long-handled brush is required, the brush itself being washed after use. As for VIP latrines, the squat-hole or pedestal seat must not be covered, so as not to interfere with the circulation of air down into the pit and up the vent pipe (for odour and fly control purposes).

Fig. 31. REED'S ODOURLESS EARTH CLOSET (ROEC)

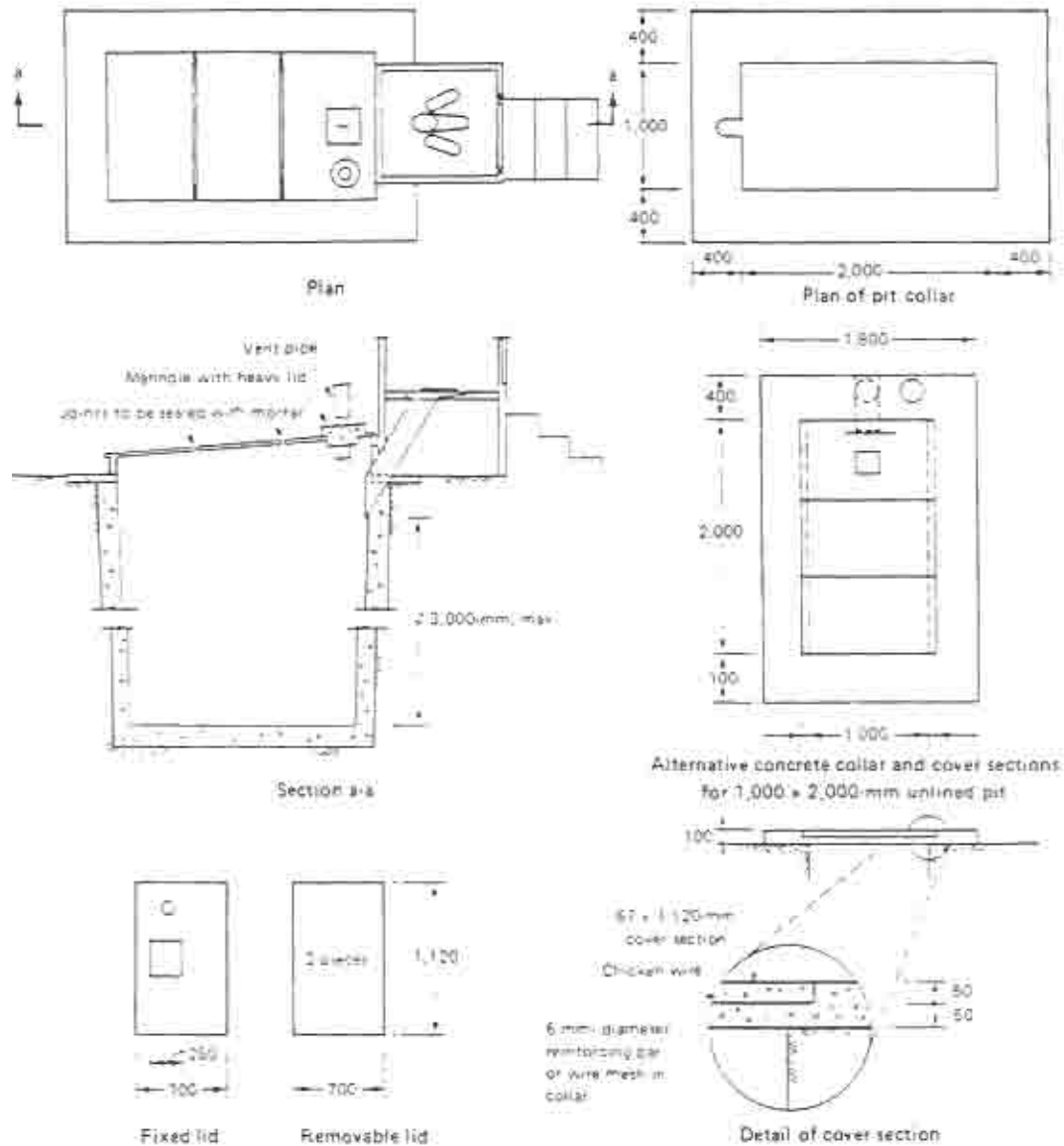

Measurements shown are in millimetres

Sanitation Guidelines

Suggestions for Construction

1. For the construction of the pit, follow the same suggestions as those given in respect of pit and VIP latrines.
2. Note that the latrine slab of a ROEC is usually elevated about 40-60cm above ground level. This facilitates the installation of the chute, as well as access to the pit for emptying.
3. It is very important that the concrete slabs and manholes be water and airtight.

Cost

The total cost of construction of a ROEC will vary considerably from country to country, depending chiefly on local costs for labour and materials, and the extent of community, or family participation and self-help.

Advantages and Disadvantages

The ROEC, like the VIP latrine, satisfies most of the sanitary requirements cited earlier. Its advantages may be summarized as follows:

- (1) Long life span
- (2) Low annual cost of operation and maintenance.
- (3) Relative ease of construction and maintenance.
- (4) All types of anal cleansing materials may be used.
- (5) Minimal odour, fly and mosquito nuisances.
- (6) Minimal water requirements (for cleaning cover slab)
- (7) Low level of municipal involvement.
- (8) Minimal risks to health.

Sanitation Guidelines

Its disadvantages include the following:

- (1) The chute is easily fouled with excreta and thus may provide a site for fly breeding if not cleaned frequently.
- (2) Frequent attention is required to ensure that the cover slabs, or manhole, fit tightly, thus preventing flies, vermin and sun rays from entering into the pit.
- (3) The greater space requirement of the ROEC make them less suitable for high density areas than the vertical drop VIP latrine.

2.1.4. Double-Vault Compost Latrine (DVC)

Description

This latrine consists of a large vault divided into two compartments, each of which is topped by a slab and a hole, as shown in Figure 32. The superstructure is also divided into two shelters with separate entrances. In practice, the vaults are filled alternately. One vault is used until it is about three quarters full. It is then filled with earth and sealed, and the other vault put into use. Ash and organic wastes (eg. leaves, grass clippings, sawdust) are added to the vault daily. When the second vault is filled and sealed, the contents of the first vault are removed and it is put into service again. The composting process requires approximately one year to make the compost hygienically safe for use as a soil fertilizer. Compost latrines require a high degree of user care and attention. They are successful when there is a demand for composted excreta (for example as fertilizer) and where there is a high degree of concern by health and agricultural authorities to the sanitary aspects of their operation and maintenance.

For proper composting no water should be added to DVC latrines except for the small amount needed to clean the squatting plate. This implies that unlined underground vaults should not penetrate groundwater. The unlined bottom of the vault should be a minimum of 1 metre above groundwater.

Components and their Design

Vaults are usually built of reinforced concrete, or with brick and mortar. They may be placed underground, as shown in Figure 32. However, it may be desirable to build them above ground (see Fig. 33) as it is easier to empty them through back openings. The squatting plate used is identical to those described previously under the pit and VIP latrine section. It must be flush and fit tightly over the outside walls to prevent the entrance of water and insects into the vault.

In some DVC latrines, urine is excluded from the vault and is either drained to a small gravel soakaway or collected for use as a liquid fertilizer. This is not recommended in most Eastern Mediterranean Region countries where the prevalence of urinary schistosomiasis is known to be high.

Each vault must have its own vent pipe whose diameter should be not less than 100 cm. The vent pipe may be made of PVC, uPVC, or ferrocement, but preferably not of galvanized iron sheets which corrode too quickly. The top of the vent-pipe is covered with a fly-screen.

Each vault must have an opening for removal of the composted contents. For underground vaults the opening will be in the cover. Above-ground vaults usually open at the rear. Openings should be constructed so that they can be tightly closed to prevent the entry of insects or animals.

The capacity of each vault is calculated on the assumption that it will be used for one full year. In addition, it is assumed that satisfactory composting requires the volume of organic material (leaves, manure, sawdust, etc.) which is added daily to be roughly four times greater than the volume of excreta:

As an example, the vault capacity of a DVC serving a family of 7 people would be calculated as follows:

- (a) Excreta production/person/year = 0.06 m^3
- (b) For a family of 7 persons = $7 \times 0.06 = 0.42 \text{ m}^3$
- (c) Volume of all other wastes = $4 \times 0.42 = 1.68 \text{ m}^3$

Sanitation Guidelines

- (d) Total, effective volume of vault = 2.10 m^3
- (e) Add 50 cm of free space below squatting plate. This space will be filled with earth at the end of one year before the second vault is put into service.
- (f) Each vault would then be 1.10 m wide, 1.60 m long and 1.70 m (i.e. 1.20 plus 0.50 m) deep.

Operation and Maintenance

The proper operation of a compost latrine requires considerable care in order to achieve the right mixture of excreta and other waste material and to prevent fly breeding and foul odours. Some experimentation may be required beforehand. Monthly inspection and prompt repairs are necessary for maintenance purposes. Only one vault is to be used at a time. The following steps should be followed:

- (1) Cover the floor of the vault with a loose layer of leaves, weeds, straw, grass clippings or sawdust to soak up the liquids; but do not use rubbish such as metal cans, glass and plastic bottles, or similar materials.
- (2) In addition to depositing human excrement, throw the daily garbage into the vault, along with cattle, horse, sheep, and/or chicken manure, as well as urine-soaked earth or straw. The latter materials are important, as urine is rich in nitrogen, an essential plant nutrient.
- (3) About once a week throw a few kilograms of grass clippings, fine-texture leaves and ash into the vault.
- (4) When the contents of the vault reach a level of 50 cm below the squatting plate, fill it with 15 cm of grass clippings and leaves and the top 35 cm with well-tamped earth.

The latrine should be cleaned at least once a week. It should not be used as a washroom as the vault will receive too much water which will impede the composting process. After a period of twelve months, during which the second vault has been in operation, the compost in the first vault may be removed through the rear wall opening and used safely as fertilizer.

Fig. 32. DOUBLE-VAULT COMPOSTING LATRINE

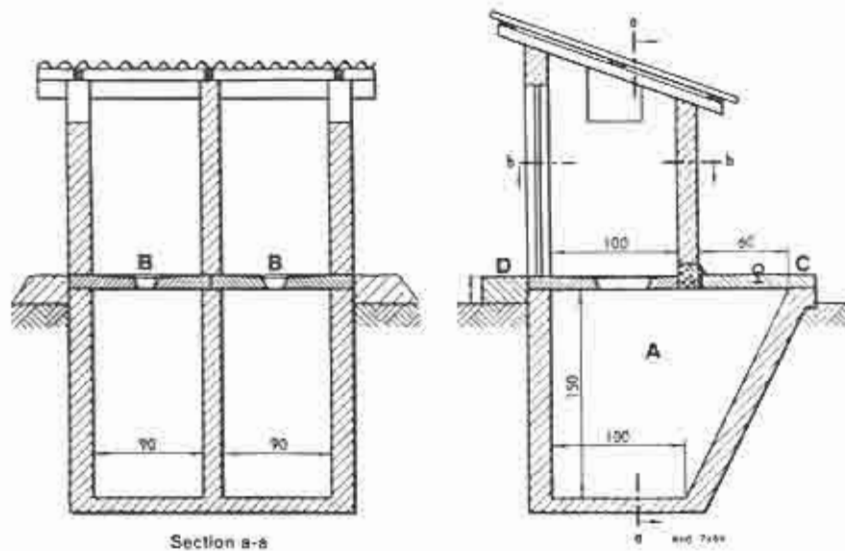

Section a-a

Section b-b

Measurements shown are in centimetres

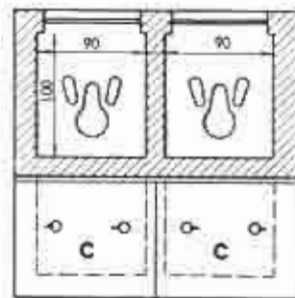

Section b-b

- A = Two vaults
- B = Squatting slabs
- C = Removable covers
- D = Step and earth mound

Sanitation Guidelines

Fig. 33. DOUBLE-VAULT COMPOSTING LATRINE USED IN VIETNAM

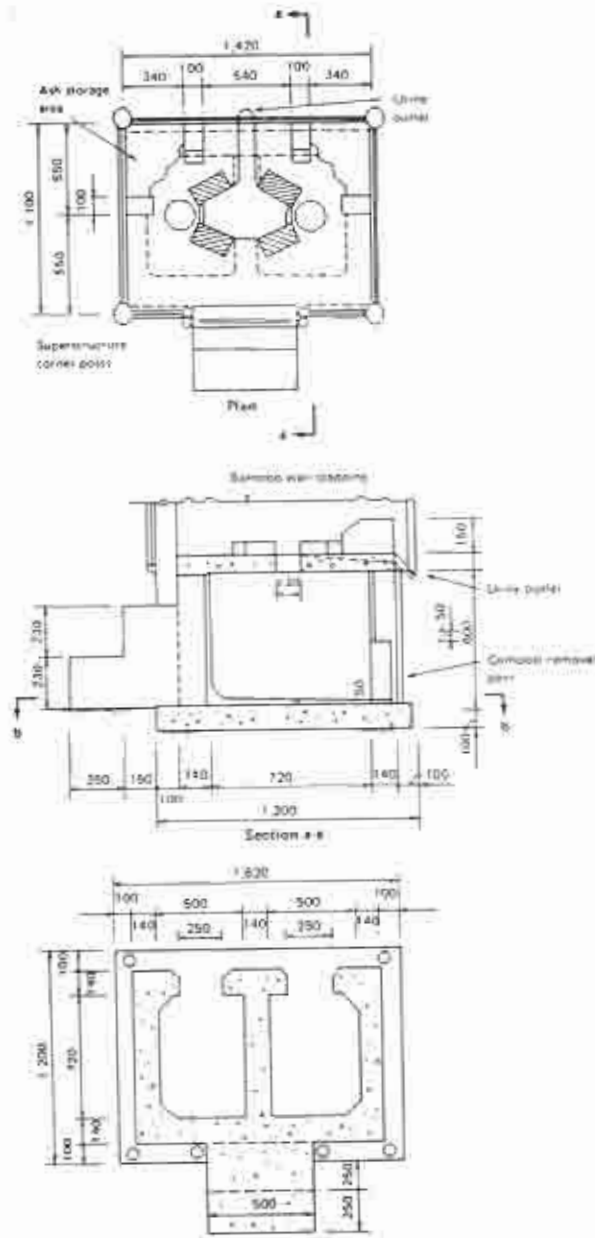

Section b-b. Measurements shown are in millimetres.

Sanitation Guidelines

Suggestions for Construction

1. The same suggestions made previously concerning construction of pit latrines, VIP latrines and ROECs, apply to the double-vault compost latrines.
2. The vaults' walls and floors may be built of reinforced concrete or with brick and mortar. In the latter case, use a mortar mix containing one part cement to three parts sand, and enough water to make a workable mixture.
3. In addition, attention should be paid to the wall separating the two vaults. This must be made watertight by plastering it on both sides with a 1.25 cm coat of a rich 1 to 3 cement-sand mixture, paying special care to seal the bottom edges of the walls.
4. In a similar manner, the vaults themselves must be watertight.
5. Cover the rear openings and seal with tar or equivalent, ensuring that the seal is strong enough to hold the weight of the accumulating compost. Do not use cement to seal the covers because eventually they will have to be removed. The covers may also need to be braced.
6. Mortar the squatting plate in place.

Advantages and Disadvantages

Proper composting in latrine vaults is complicated and users may find it difficult to understand the processes involved. Close supervision by health and agriculture officials and systematic education and follow-up are required during the first two or more years of application. Furthermore, latrine vault composting is not free of hazards and requires attention. Proper location is essential to prevent pollution of groundwater and the entrance of water into the vault.

Under proper conditions of operation, this method will satisfy most sanitary requirements. It is more expensive than the ordinary pit latrine since it involves the construction of two or more vaults.

Another difficulty with the double vault composting latrine is that both compartments are often used simultaneously, thus defeating their purpose. DVC toilets are generally unsuitable for high-density housing areas, in communities where users

are unwilling to handle the composted humus and where there is no local demand for the humus produced.

2.2. Water-carried Methods of Excreta Disposal

Water-carried or wet systems for excreta disposal require a perennial water source for flushing. All water-carried systems use water to seal off the latrine pit which eliminates odour and fly problems. The receptacles of the water-carried methods can vary from simple leaching pits to septic tanks, or even small bore sewer systems.

2.2.1. Pour-Flush (PF) Toilet

Description

The pour-flush toilet, also known as the water-seal latrine, consists of a squatting slab into which a specially made pan is incorporated, as shown in Figure 34. The pan has a bottom slope of 25° to 30° to the horizontal and a 2 cm. waterseal trap (U-trap). After use it is flushed by hand using a small container holding about 1.5 to 2 litres of water. Such a slab may be installed directly over or connected by a pipe or drain to a leach pit. If sufficient space exists two leach pits are used alternately. Because of the waterseal flies cannot gain access to the excreta, and odours cannot escape. With simple care the pour-flush toilet is a satisfactory and hygienic sanitation system which can be located inside or outside a house. It is a particularly appropriate technology wherever water is used for anal cleansing.

Components and their Design

Squatting pan

Details of one type of squatting pan are shown in Figure 35. The horizontal length of the pan should be at least 425 mm and the trap should be 70 mm diameter with a 20 mm waterseal. The pan can be of ceramic, glass fibre-reinforced plastic (GRP), PVC, high-density polyethylene (HDPE), mosaic or cement concrete. Ceramic or plastic pans have many advantages over the concrete ones. They are smooth and require less water for flushing. Plastic pans are cheaper, lighter and easier to transport than ceramic ones. Concrete pans are heavy, difficult to transport and become

are unwilling to handle the composted humus and where there is no local demand for the humus produced.

2.2. Water-carried Methods of Excreta Disposal

Water-carried or wet systems for excreta disposal require a perennial water source for flushing. All water-carried systems use water to seal off the latrine pit which eliminates odour and fly problems. The receptacles of the water-carried methods can vary from simple leaching pits to septic tanks, or even small bore sewer systems.

2.2.1. Pour-Flush (PF) Toilet

Description

The pour-flush toilet, also known as the water-seal latrine, consists of a squatting slab into which a specially made pan is incorporated, as shown in Figure 34. The pan has a bottom slope of 25° to 30° to the horizontal and a 2 cm. waterseal trap (U-trap). After use it is flushed by hand using a small container holding about 1.5 to 2 litres of water. Such a slab may be installed directly over or connected by a pipe or drain to a leach pit. If sufficient space exists two leach pits are used alternately. Because of the waterseal flies cannot gain access to the excreta, and odours cannot escape. With simple care the pour-flush toilet is a satisfactory and hygienic sanitation system which can be located inside or outside a house. It is a particularly appropriate technology wherever water is used for anal cleansing.

Components and their Design

Squatting pan

Details of one type of squatting pan are shown in Figure 35. The horizontal length of the pan should be at least 425 mm and the trap should be 70 mm diameter with a 20 mm waterseal. The pan can be of ceramic, glass fibre-reinforced plastic (GRP), PVC, high-density polyethylene (HDPE), mosaic or cement concrete. Ceramic or plastic pans have many advantages over the concrete ones. They are smooth and require less water for flushing. Plastic pans are cheaper, lighter and easier to transport than ceramic ones. Concrete pans are heavy, difficult to transport and become

Sanitation Guidelines

rough and unattractive after use due to the action of uric acid. However, they are less expensive.

Connecting drain or pipe to leach pits

The trap should be connected to the pits either by a pipe or a covered drain. If a pipe is used, a junction chamber of minimum internal size 250mm x 250 mm should be provided at the junction point, as shown in Figure 36. Asbestos cement may be used as it is smooth and often cheap. Alternatively, a drain can be made with a semicircular floor of bricks or stones with a minimum size of 75 mm x 75 mm, as shown in Figure 36. The slope provided should be 1 in 5 to 1 in 15. Bends and curves in the drain should be avoided. The inlet pipe or drain should project a minimum of 100 mm into the pit.

Leach Pit

The size of a leach pit depends upon a number of factors. These include: number of users, cleaning interval, soil properties (including its permeability), water table level, and the quantity of water used for flushing and cleaning.

When the squatting plate is placed directly over the disposal pit, the latter is designed and built in much the same manner as for ordinary pit or VIP latrines. Since water is used in the pour flush toilet it will usually be necessary to line the walls of leaching pits with brickwork, stonework or concrete to prevent the saturated soil from collapsing. If the squatting plate is installed inside the dwelling, the pit is dug outside and assumes the shape and design of a leaching cesspool pit (see Figures 37 and 38).

Fig. 34. POUR-FLUSH WATER-SEAL LATRINE

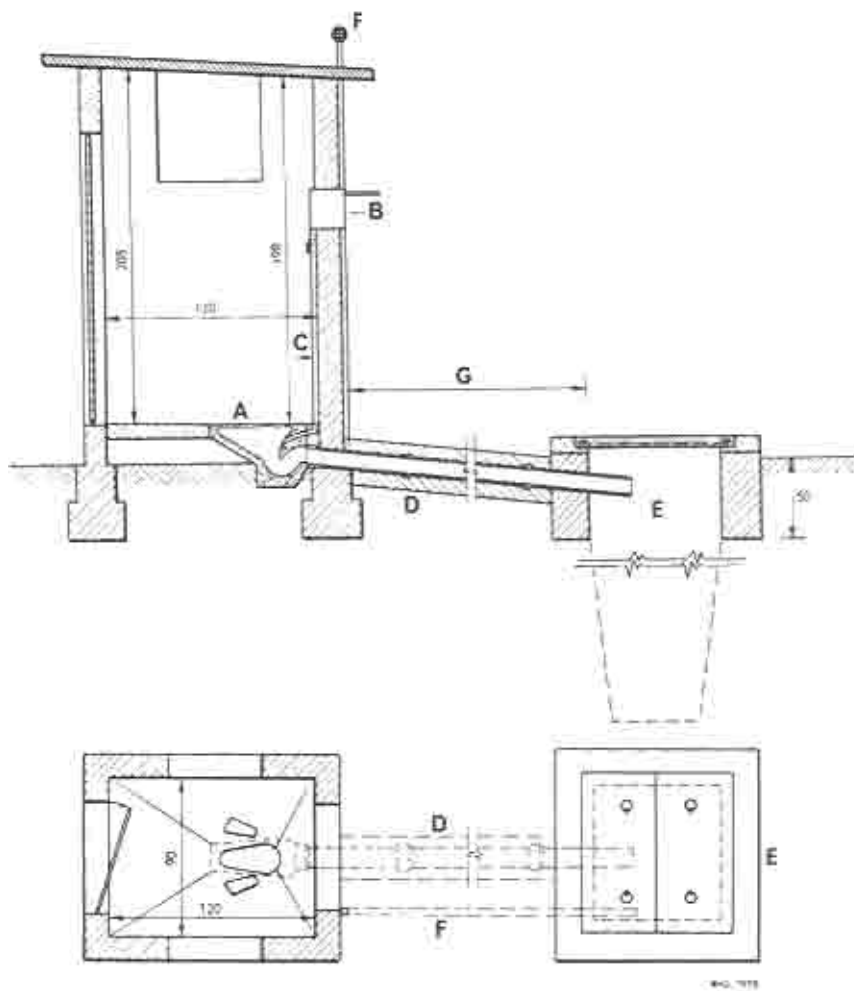

Measurements shown are in centimetres

- A - Water-seal bowl with S trap
- B - Water tank, filled by hand and provided with plug cock and overflow pipe
- C - Water pipe leading from tank to bowl for flushing purposes
- D - Drain pipe embedded in concrete leading to seepage pit
- E - Seepage pit
- F - Ventilation pipe for pit
- G - Distance between bowl and pit should be as short as possible

Fig. 36. DETAILS OF DRAIN AND JUNCTION CHAMBER

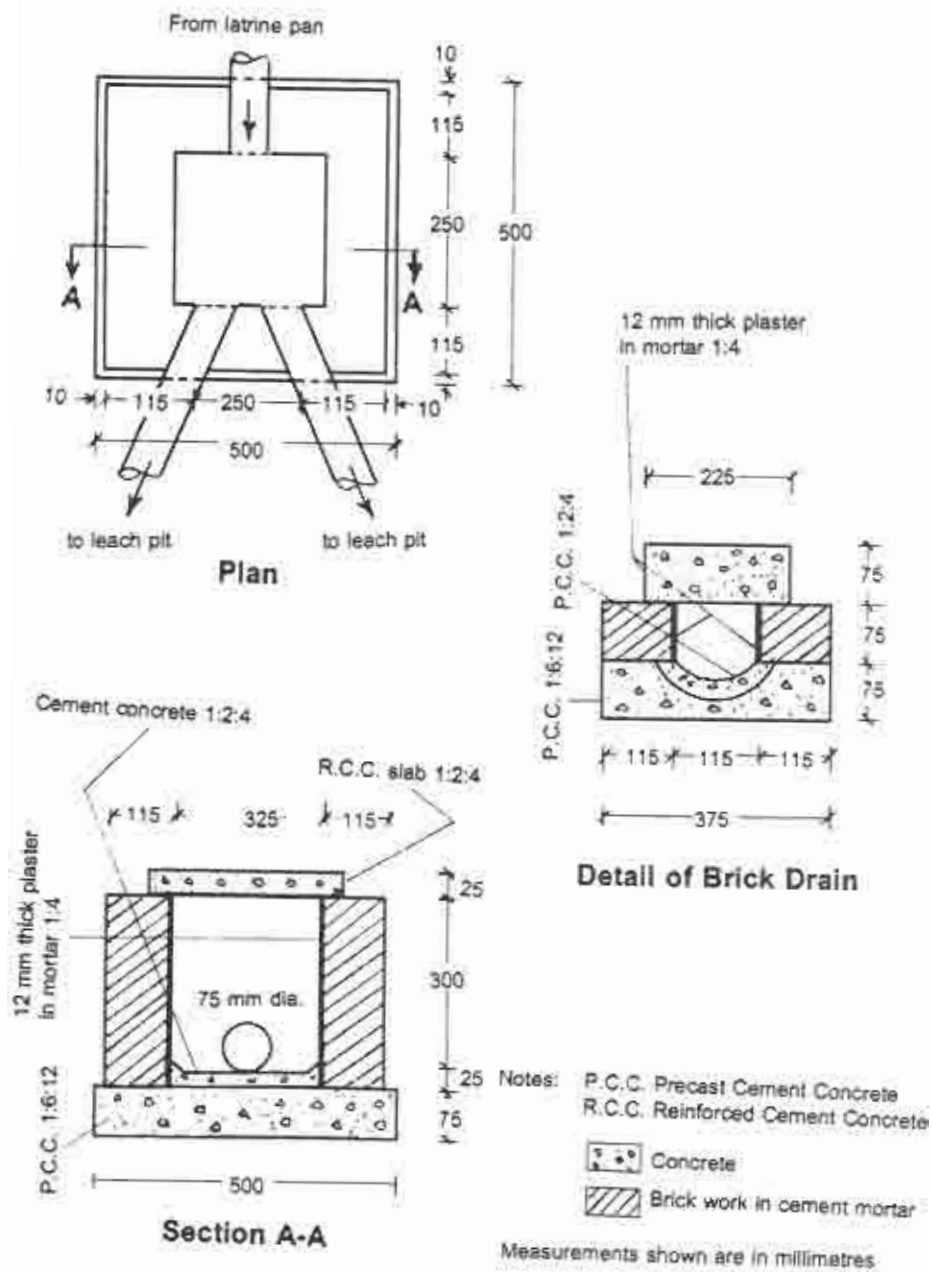

Sanitation Guidelines

Fig. 37. DETAILS OF SUPERSTRUCTURE

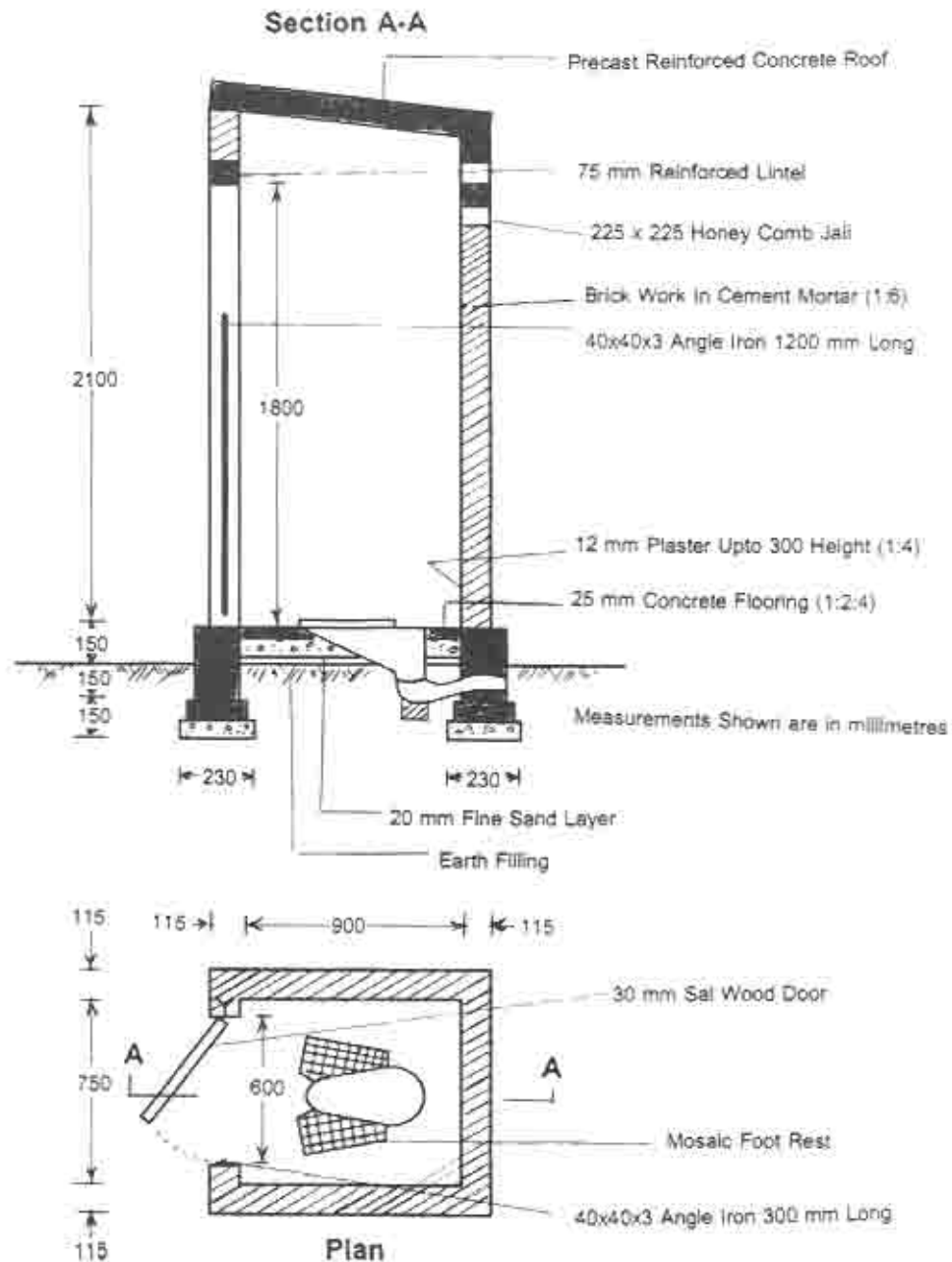
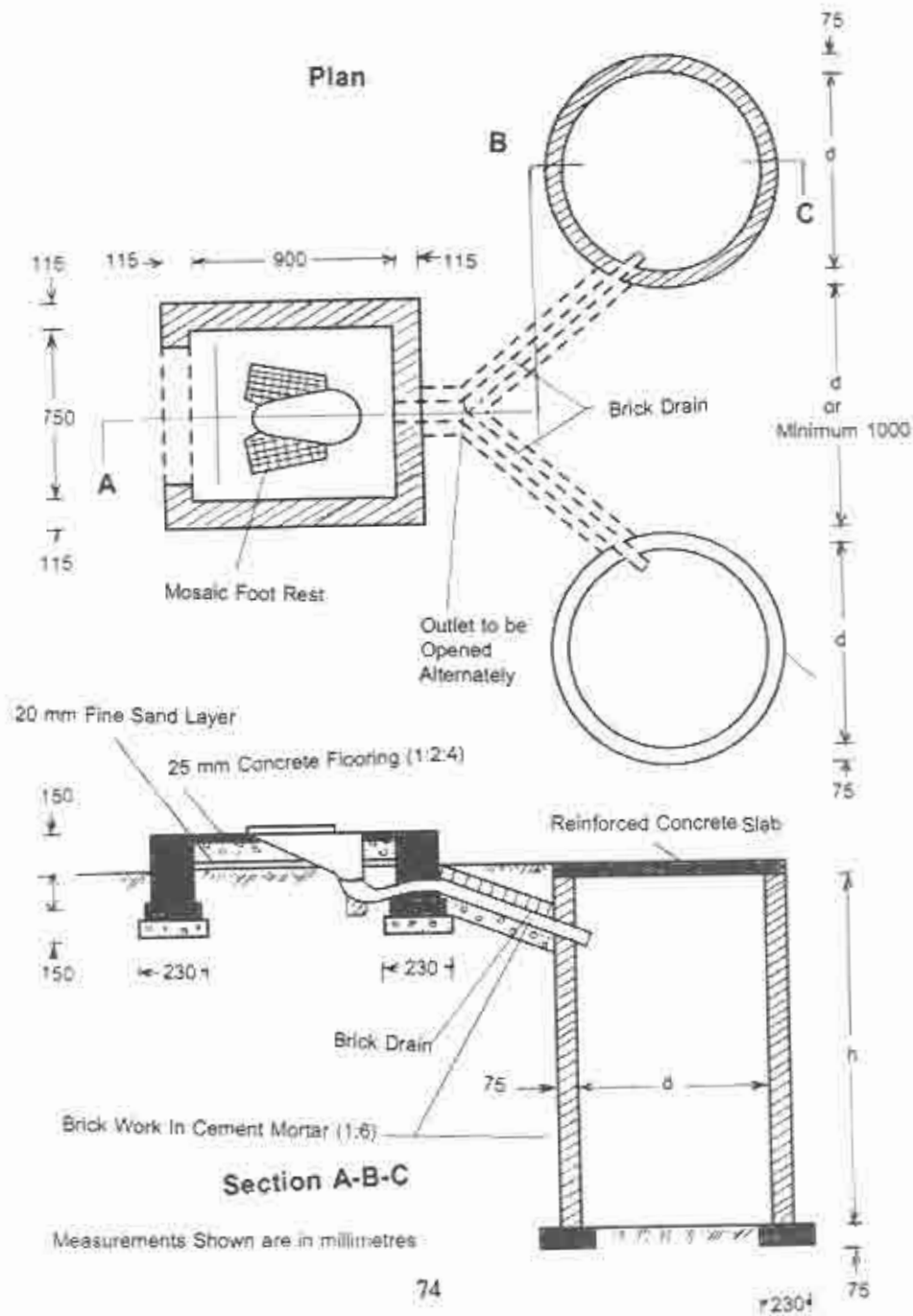

Fig. 38. DESIGN OF LOW COST WATER SEAL LATRINE WITHIN THE PREMISES



Sanitation Guidelines

The leach pit may be dry or wet. It is wet if it penetrates the groundwater table throughout the year. The effective volume of a pit is the volume below the level of the pipe or drain which brings in the excreta and flush water. Effective depth is the depth below the level of the inlet pipe. Assuming that a leach pit will serve for three years before being emptied, its effective volume for different numbers of users, under dry or wet conditions, is shown in Table 2.

Table 2 EFFECTIVE VOLUME OF LEACHING PIT UNDER DRY AND WET CONDITIONS

| Number of users | Effective volume in cubic meters for three years | |
|-----------------|--|--------------------------|
| | Pit under dry conditions | Pit under wet conditions |
| 5 | 0.68 | 1.0 |
| 6 | 0.81 | 1.2 |
| 10 | 1.36 | 2.0 |
| 15 | 2.04 | 3.0 |

The pit shape may be circular or rectangular. However, circular pits are preferable as they are more stable and cost less. Pits are usually between 0.9 and 1.3 metres in diameter, and between 1.0 and 1.6 metres in depth. A free space, of not less than 25 cm above the inlet pipe, should be provided. Smaller (but not less than 0.8 metres in diameter) and deeper pits may be dug where available space is restricted.

The minimum space between two pits should be equivalent to at least the effective depth of the pits. The minimum distance of the leach pits from foundations of existing buildings depends upon the soil characteristics, the depth and type of the foundations of the building, and pit depth. The greater the pit depth, the greater the distance from the building foundations should be. As an indication, a pit 2 metres deep in sandy clay should be a minimum of 0.9 metres from the nearest building foundation. However, in clayey sand it may be located as little as 0.6 metres from the nearest building.

Leach pits should not be located in water-logged areas or in areas subject to flooding. Wet leach pits represent a health hazard with respect to possible risk of pollution of drinking water sources. Consequently, they should not be less than 30 metres from a drinking water source. Dry leach pits, provided that they are well

Sanitation Guidelines

clear of the groundwater table, should never be less than 15 metres from a drinking water source.

Pits should be lined with honeycomb brickwork, stone in cement or lime mortar, or random stone masonry without any mortar. Alternatively, the pit can be lined with burnt clay rings or concrete rings. Under special circumstances, lining can be bitumen-coated bamboo matting, but the life of such lining is limited. In brick lining, the width of openings should be 7.5 cm. Whatever the lining material used, the lining above the top of the inlet pipe or drain up to the top of the leaching pit, should be solid masonry (i.e. with no openings).

Pit covers should be water tight, and built of reinforced concrete, stone slabs or other suitable locally available material.

Superstructure

The superstructure should be economical and affordable.

Suggestions for Construction

The pour flush toilet components made from ceramics or plastics usually have the floor slab, pan and trap made as a single integral unit, greatly simplifying construction procedures. The ceramic type is commercially available in most countries of the Eastern Mediterranean Region and procedures for its installation in a concrete floor are quite well known by local artisans.

Figures 34 to 38 show construction features and details of pour flush toilets. These recommendations are based on a design developed in India where this type of toilet has been in use since the late 1940s. The following suggestions relate to this inexpensive type of pan and trap sections which may be appropriate for sanitation programmes in rural areas.

1. Determine where the pan is to be located and compact the underlying earth, excavating where necessary, for placing the pan and trap.
2. Assemble the pan and trap, caulking the joint with spun yarn soaked in neat cement mortar. Fill the joint and make a fillet with 1:1 cement:sand mortar.

Sanitation Guidelines

3. Place a brick or flat stone at the point where the bottom of the trap will rest, raising or lowering the tamped earth as necessary to bring the top of the pan to the proper final height.
4. Fill around the pan and trap, first with a 50 mm layer of gravel or crushed brick followed by a 20 mm layer of sand. A space should be left for a 25 mm layer of concrete floor.
5. Tamp the fill material. Place the final layer of concrete. Vibrate and work the concrete to make it dense. Smooth the surface so that there is a slope of about 3% towards the pan. Place the footrests, as shown in Figure 34, with their tops at least 10 mm above the adjacent slab. Allow the concrete to cure for 6 to 8 hours then use a steel trowel to give a smooth finish.
6. The leaching pits should then be lined with either brickwork, stone masonry, dry stone pitching or burnt clay rings. The open spaces between bricks or stones should be about 115 x 75mm in size. The top part of the pit wall, above the inlet pipe, must be made watertight.
7. All pipe joints and connections with the waterseal trap, the junction chamber and the leaching pits, must be watertight.
8. One drain or pipe should be blocked at any one time, so that the discharge from the squatting pan goes to one pit only.
9. Make sure that there is no blockage of the squatting pan and trap due to falling mortar during construction. In addition, ensure that the pan, trap and footrests have been set correctly.

Operation and Maintenance

The most important daily maintenance required is to ensure that the slab and pan are kept clean. A bendable brush is useful for cleaning the waterseal trap. Sullage from laundry, bathing or the kitchen should not be disposed of into the latrine unless the leaching pit has been designed to receive such wastewater. No solid waste or any solid anal cleansing material should be put into the pan as it is likely to cause blockage.

Sanitation Guidelines

Operation and Maintenance

The most important daily maintenance required is to ensure that the slab and pan are kept clean. A bendable brush is useful for cleaning the waterseal trap. Sullage from laundry, bathing or the kitchen should not be disposed of into the latrine unless the leaching pit has been designed to receive such wastewater. No solid waste or any solid anal cleansing material should be put into the pan as it is likely to cause blockage.

The first indication that the leaching pit is full is usually given by the inability to flush the pan. Once it is established that this is not due to blockage then it is necessary to seal off the leaching pit, if it is designed not to be emptied. For the single offset leaching pit an emptying service has to be called. This indication is usually given rather late, as the outlet of the waterseal is normally less than 50 cm below the ground, and so the recommendation to cover the pit with at least 0.5 metre of earth cannot be met. The desludging service may not be available at short notice and overflowing may therefore occur. It is advisable to have some other means of indicating the level of the pit contents, such as a marked stick which fits in the cover slab.

Advantages and Disadvantages

These may be summarized as follows:

Advantages:

1. The water-seal (pour-flush) latrine, when properly operated and maintained, satisfies all sanitary and aesthetic criteria.
2. It is especially suitable where water is used for anal cleansing.
3. It can be installed near or inside the dwelling.
4. It minimizes contact with flies and vermin.
5. The odour nuisance is kept to a minimum.
6. It is entirely safe for children.

Sanitation Guidelines

7. It is fairly simple and inexpensive to build.
8. It is moderately simple and inexpensive to operate and maintain.

Disadvantages:

1. It can be used only in areas where water is obtainable throughout the year (a small volume will suffice).
2. It requires a period of intensive education in its proper use and cleaning and continued follow-up by sanitation authorities.
3. It costs slightly more than ordinary pit latrines, but less than aqua latrines.
4. In many rural areas of the world, it would require a change in customary use of cleaning materials. For instance, mud balls, corncobs, or stones cannot be used for anal cleansing in pour-flush latrines as they would block, or destroy, the waterseal trap.
5. It is not readily applicable in areas with impermeable soils.
6. For the off-set leaching pit a balance has to be found between desludging costs and construction costs. In most cases it is better to dig a deep leaching pit as the organization of desludging services is generally inadequate.

2.2.2. Aqua Privy

Description

The aqua privy consists of a squatting plate situated immediately above a small septic tank that discharges its effluent to an adjacent soakaway (see Figures 39 and 40).

The squatting plate has an integral drop pipe, of 10 to 15 cm diameter, the bottom of which is 10 to 15 cm below the water level in the tank. In this manner a simple water seal is formed between the squatting plate and the tank contents which is necessary to prevent fly and odour nuisance in the toilet. In order to maintain this water seal it is essential that the tank be completely watertight and that the user add

Sanitation Guidelines

sufficient water to the tank via the drop pipe to replace any losses. A superstructure is provided for privacy and a small vent pipe is normally incorporated to expel the gases produced in the tank.

The excreta are deposited directly into the tank where they are decomposed in the same manner as in a septic tank. There is, as with septic tanks, a gradual accumulation of sludge (approximately 0.03-0.04 cubic metres per user per year), which should be removed when the tank is two-thirds full of sludge.

Components and their Design

The Tank

The function of the tank is to receive, store, and digest the excreta, to keep them away from flies and other vermin, and to render them innocuous. The shape of the tank depends on local construction facilities and materials; it may be round, square, or rectangular. Concrete tanks built on location are usually square or rectangular since formwork for these shapes is easier to construct. Round tanks may be made of plain concrete sewer pipes 90 cm or 120 cm in diameter placed vertically in an earth pit and sealed at the bottom with concrete.

The size of the tank varies with the number of persons for whom it is designed and with the time interval allowed between sludge removal operations. The tank volume is usually calculated on the basis of 0.12 cubic metres per user, with a minimum size of 1 cubic metre. Desludging is normally required every 2 to 3 years when the tank is two-thirds full of sludge. The liquid depth in the tank is normally 1.0 to 1.5 meters in household units. As an example, the volume of an aqua privy serving 10 persons, assuming desludging every 2 to 3 years, will be $10 \times 0.12 = 1.2$ cubic metres.

This corresponds to a rectangular tank with a liquid depth of 1.10 m, inside length of 1.10 m and inside width 1.00 m. A free space of 30 cm should be provided above the water level (and below the squatting plate) for the normal accumulation of scum. The total tank depth in this instance would be 1.40 metres. The fact that aqua privy tanks are not very deep is an advantage from the point of view of construction, especially in areas where groundwater or rock is close to the surface.

Materials commonly used for the construction of the tank include plain or reinforced concrete, or brick or stone masonry with a plaster cover. Concrete is the

Sanitation Guidelines

best material to ensure water-tightness. In addition, it is permanent and relatively easy to work with. In areas where bricks and stones are easily obtained they may be cheaper to use. However, they require a coat of rich cement plaster to make them water-tight.

Tank Ventilation

In aqua privies, where the decomposition of excreta is entirely anaerobic in nature, it is necessary to provide a vent pipe for the escape of the large volume of gas which is normally produced by fermentation (see Figure 39). Its opening in the tank should be just below the slab and away from the scum which might choke it. Its outside opening should be above the roof of the superstructure and away from doors and windows of neighbouring houses, in order to avoid odours. A 7.5 cm (3.in) pipe will be satisfactory under most circumstances.

The Squatting Plate

The squatting plate is provided with a short length of pipe, as shown in Figure 40. Depending upon its design, it may or may not include a bowl or pan. Since the aqua privy is permanent in nature, the floor is usually made of a durable material such as concrete. This material lends itself well to mass production methods. Typical slab designs for aqua privies are shown in Figures 40 and 41. The slab surface has a small slope from the edges towards the hole or bowl to ensure that the water used for cleaning, flushing, ablution or cleansing purposes drains into the tank.

The bowl is usually made of cement and is pre-cast with the slab. The chute or drop-pipe is made of earthenware, plastic or vitrified clay. Cement pipes may also be used, but will not last as long as other materials since the lower extremity will tend to disintegrate along the line of contact with the liquid in the tank. The size of the pipe varies from 10 cm to 20 cm in diameter, depending on the anticipated use and maintenance of the privy. If the privy is properly used, the smaller size will be satisfactory. However, in places where stones, mud balls, or sticks are likely to be used for anal cleansing, the larger size will tend to reduce blockage of the pipe. The smaller pipe size will prevent the water from splashing and will normally be free of crust-forming scum when the latrine is in constant use. Pipes larger than 20 cm expose too much of the water surface, over which mosquitoes may lay their eggs. In addition, splashing water is likely to be a nuisance.

Fig. 39. THE AQUA PRIVY

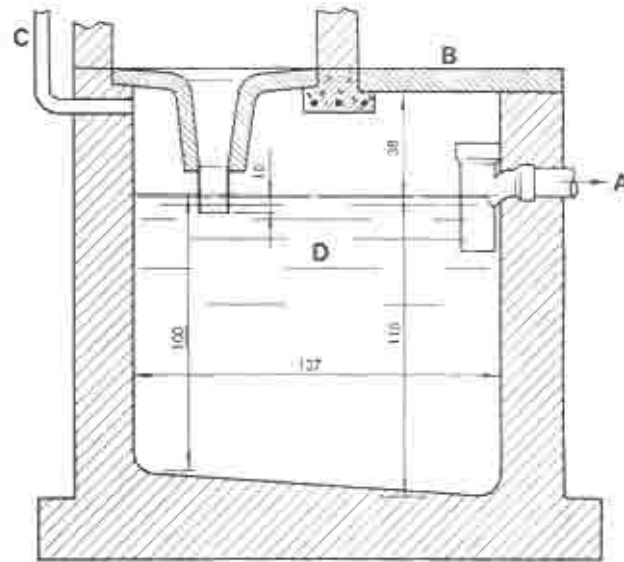

Section a-a

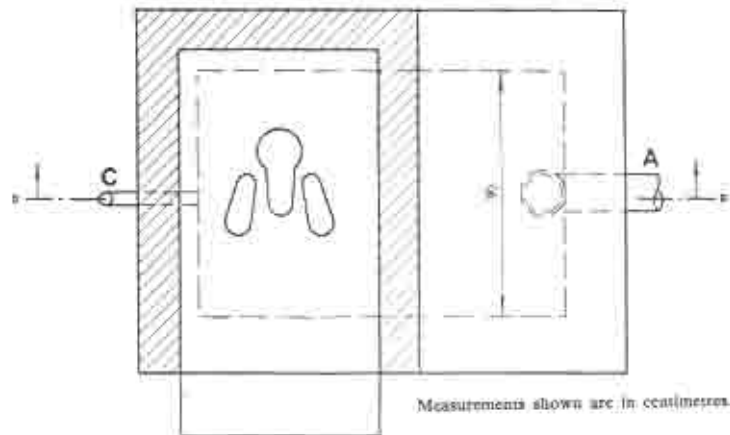

Measurements shown are in centimetres.

- A = Outlet to soakage trench or soakage pit
- B = Removable, reinforced concrete cover slab
- C = 2.5-cm- (1-in.-) diameter pipe ventilator
- D = Capacity of tank 1340 litres (295 imp. gal.)

Sanitation Guidelines

Fig. 40. SQUATTING PLATE AQUA PRIVY

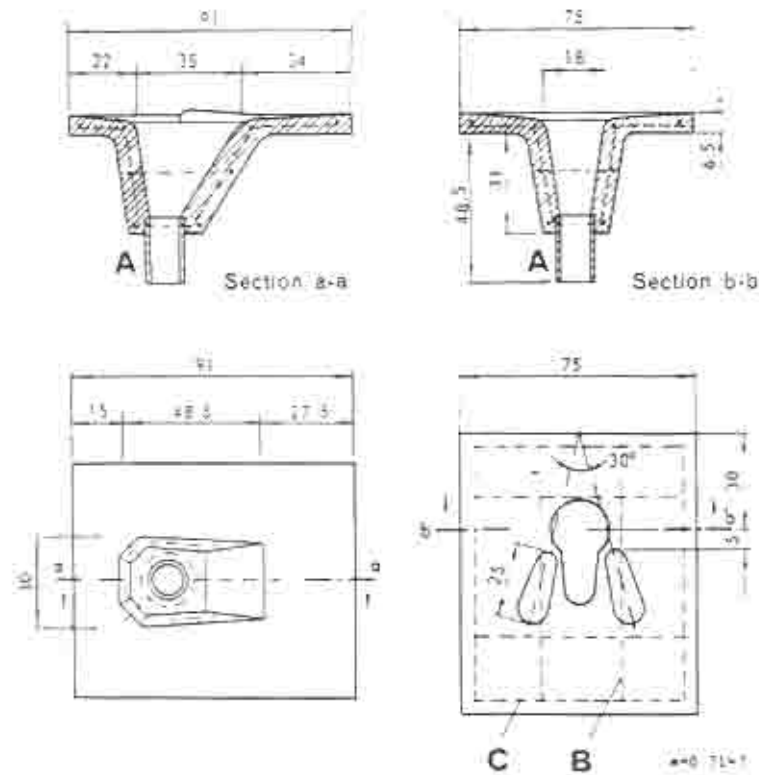

- A = Glazed earthenware pipe cut to 22 cm length
- B = Reinforcement, 0.9 cm rod
- C = Reinforcement 0.6 cm rod

Measurements shown are in centimetres

In these latrines, perhaps more than in pit latrines, there is a great need for foot-rests, because the floors of aqua privies are likely to be wet from splashing of cleansing and ablution water. Foot-rests should be properly designed to ensure rapid and easy drainage of water towards the hole.

Sanitation Guidelines

Fig. 41 BOWL FOR PUBLIC AQUA PRIVY

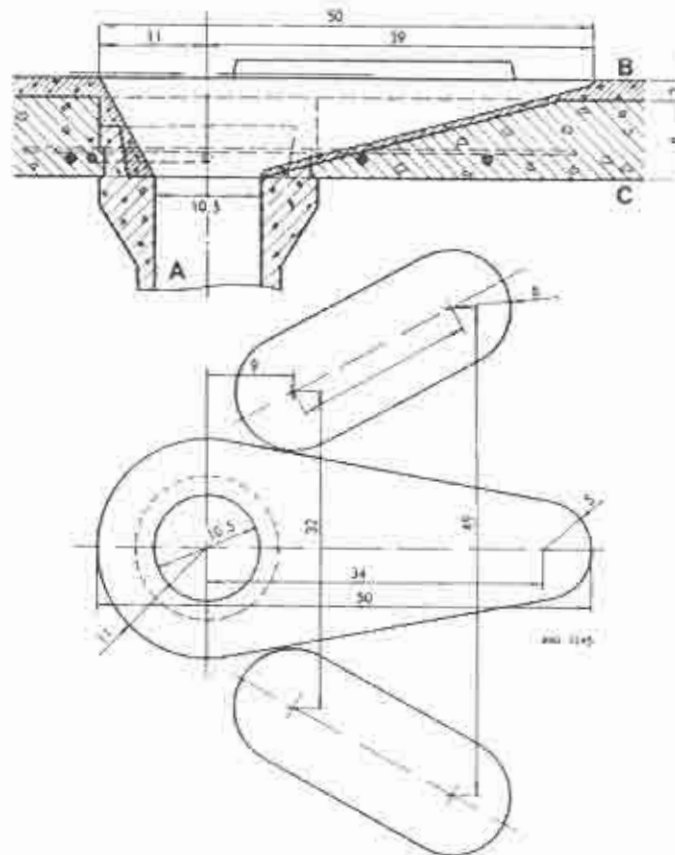

Measurements shown are in centimeters.

- A = Drop pipe
- B = Rich sand-cement mixture
- C = Reinforced concrete floor

The Disposal of Effluents

For each litre of water added to the water-tight tank of an aqua privy, a corresponding amount of "sewage" must be evacuated and disposed of as effluent. This effluent is loaded with finely divided, decomposing faecal matter.

Sanitation Guidelines

It may also contain harmful bacteria and the ova of parasitic worms. Furthermore, because of the small size of the tank, there is a possibility that water may short-circuit from the chute to the outlet pipe. For these reasons, the effluent, though small in volume, should never be permitted to run freely over the ground or in open ditches. It should not be used for irrigation of garden crops which will be eaten raw.

The average amount of water to be evacuated from an aqua privy is about 4.5 litres per person per day. However, a capacity of 10 litres per person per day is recommended for its design. This figure will vary with the degree of availability of water for cleaning purposes and should be corrected by field observations. For example, when an aqua privy is provided with a water tap inside the superstructure, the tank may be expected to receive much more water than mentioned above. In such circumstances, an effluent disposal system designed for a rate of 10 litres per person per day would soon be overloaded and cease to function.

The effluent is carried away through a 10 cm pipe inserted into the side of the tank at the correct level. In order to prevent the scum from entering the disposal pipe, the outlet is fitted with a tee or an elbow, as shown in Figure 42. For small installations the disposal of effluent is usually through seepage pits or subsurface irrigation.

The size of a seepage pit (or soakaway) should be calculated assuming an infiltration rate of 10 litres per square metre of sidewall daily. For example, if an aqua privy serves 15 people, its effluent may reach 150 litres per day (i.e. 15 people x 10 litres per person). The required sidewall area of the seepage pit will be 15 square metres (i.e. 150 litres per day divided by the design infiltration rate of 10 litres per square metre per day). If the seepage pit is square, each sidewall will have a surface area of 3.75 square metres (i.e. 15 square metres divided by four sides). This corresponds to a pit 1.50 metres square and 2.50 metres deep below the inlet pipe.

The other common method of disposal of aqua privy effluent, subsurface irrigation, is also commonly used for the disposal of effluent from septic tanks. It is described in the section entitled "Septic Tank" under the title "Subsurface Irrigation".

Fig. 42. FAMILY-TYPE AQUA PRIVY USING 90 cm OR 120 cm DIAMETER CONCRETE SEWER PIPE FOR THE TANK

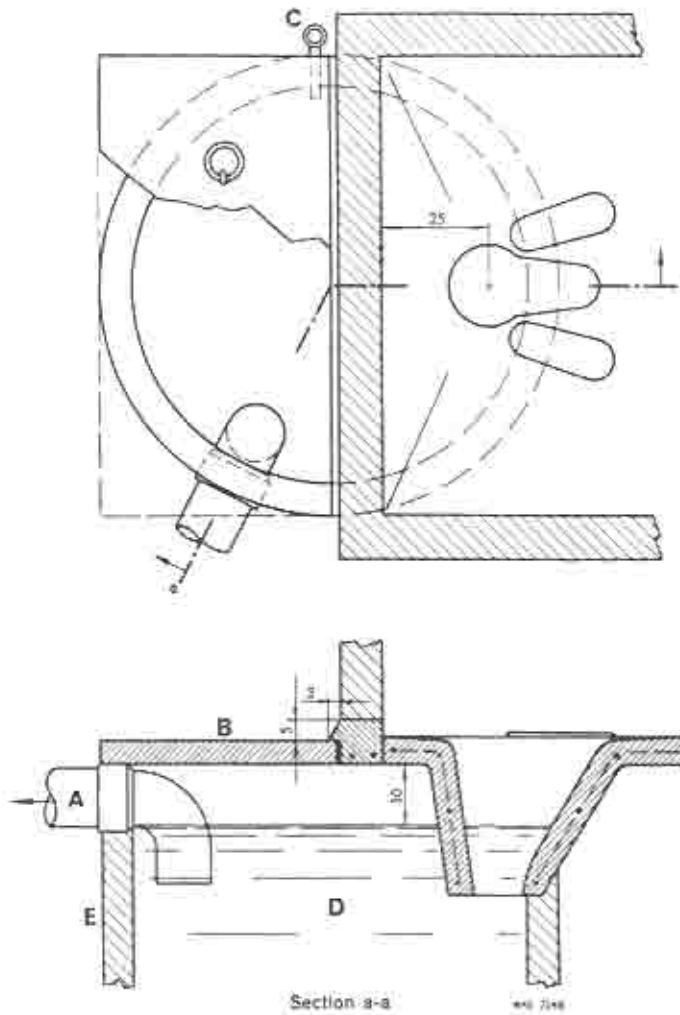

- A = Outlet to soakage trench or soakage pit
- B = Removable, reinforced concrete cover slab
- C = 2.5-cm- (1-in.-) diameter pipe ventilation
- D = Tank capacity varies with diameter and length of sewer pipe used
- E = 90-cm- or 120-cm- diameter concrete sewer pipe, 90 cm long or more, sealed with concrete at lower end

Sanitation Guidelines

Operation and Maintenance

The first operation in starting an aqua privy is filling the tank with water up to the invert level of the effluent pipe. Some digested sludge, taken from another privy, may be added in order to seed the water with the right types of bacteria and micro-organisms to carry out the decomposition process. This is not absolutely necessary, but, if the tank is not seeded, a minimum of six to eight weeks is required to reach an efficient level of operation. Once established, the aqua privy will work satisfactorily provided it is in daily use. In areas where anal cleansing with water is not practised, the tank should receive the small amount of water necessary for it to function correctly if the slab and bowl are given a daily wash down with two or three buckets of water - i.e., approximately 25-40 litres.

The digested human waste deposited in the tank will be considerably reduced in volume. After about 3 years the digested sludge in a family-size installation will need to be removed as it will occupy 50 to 60 per cent of the tank water capacity. Sticks, mud balls, coconut husks, and similar cleansing agents will not disintegrate and will cause the tank to fill more rapidly. In areas where such cleaning materials are used the sludge will have to be removed with greater frequency. Provision should be made in the design of an aqua privy for periodic sludge removal through an airtight inspection cover. Such an inspection cover may be located either inside or outside the superstructure. It should facilitate easy access to the sludge, as well as the outlet tee and the vent pipe opening, both of which may need to be cleaned of scum or other solids. The inspection cover should be tightly fitted to prevent the entry of flies and mosquitoes. It should be easily accessible, and not be buried under an earth cover and forgotten. The sludge removed will contain some undigested matter which is still offensive and presents a health hazard. This should be buried in shallow trenches, 40 cm deep.

One difficulty often experienced with poorly maintained aqua privies is that the drop-pipe gets choked with fresh faeces upon which flies lay their eggs. Maggots then hatch and migrate all over the interior walls and ceiling of the superstructure, creating a considerable nuisance to the users. A plain stick may be used to push the faeces down.

Maintenance of the water seal has been a problem with conventional aqua privies, except in some Islamic communities where the water used for anal cleansing is sufficient to maintain the seal.

Sanitation Guidelines

In all communities it is necessary for the vault to remain water tight. However, in some areas people are either unaware of the importance of maintaining the seal or they dislike being seen carrying water into the toilet. If the seal is not regularly maintained, there are problems with odours, flies and mosquitos. This is one reason why some authorities hesitate to recommend the aqua privy as a sanitary means of excreta disposal.

Wherever this type of latrine is used it is essential that the sanitation technician and the local health authorities implement an on-going programme of health education, particularly with school children. In addition, there must be regular sanitary inspections, in order to ensure that aqua privies are properly used and maintained.

The Self-topping or Sullage Aqua Privy

In communities where houses are provided with a water supply system, the daily sullage may be disposed of through the aqua privy (see Figure 43). Such a system helps to maintain the water seal. A sullage compartment having a volume of 0.5 cubic metres is connected to the aqua privy tank with a horizontal pipe in order to avoid disturbing the tank contents. The effluent of the self-topping aqua privy contains a much smaller concentration of suspended solids and it will be absorbed more easily by the soil through the walls of the seepage pit. The infiltration rate through the seepage pit walls may be taken as 30 to 50 litres per square metre of wall per day.

Cost

Costs of both types of aqua privies are higher than the costs of pit or VIP latrines or pour-flush toilets, because both a watertight tank and a seepage pit are needed. There is also the additional cost of emptying the aqua privy's tank every three years.

Suggestions for Construction

A properly operated aqua privy is a clean and odourless installation which may be safely located close to a dwelling. If proper operation and use cannot be guaranteed, the minimum distance of about 3 metres from the dwelling should be increased. It should be located downhill and at least 15 metres from the nearest source of drinking water supply.

Sanitation Guidelines

Similarly, the seepage pit should be downhill and at least:

- 30 metres from nearest source of water supply (i.e. a spring or well)
- 6 metres from nearest building
- 3 metres from nearest property line
- 3 metres from nearest trees or bushes.

The pit (or trench) floor should be at least 1 m above highest groundwater level. The minimum distance between the aqua privy tank and the seepage pit should be 3 metres in ordinary soils. This distance should be increased if the soil permeability is very high (e.g. sandy soil). It may be reduced if the soil is impervious (e.g. clayey loam or clayey sand).

Depending on local conditions and availability of materials and skilled workers the following steps are recommended:

- A. For concrete construction (see Figure 44)
 1. Use location map to lay out the structures, keeping the minimum recommended distances from dwellings, water sources, property lines, etc.
 2. Dig the hole for aqua privy vault, allowing a working area 30 cm wide all around.
 3. Level and tamp down the bottom of the vault. Spread 50-100 mm of gravel, pebbles or broken stone on the bottom.
 4. Build formwork for the floor.
 5. Mix concrete to the correct proportions (cement:sand:gravel:1:1:4), use water to make a workable mix.
 6. Half fill the formwork with concrete. Put reinforcement in place (mild steel rods, wire mesh or bamboo strips), and fill the remainder of the formwork. Smooth the surface with a trowel.
 7. While concrete floor is setting, build formwork for the slab to be placed on top of the completed walls. (see Figure 44a)

Sanitation Guidelines

8. Half fill the slab formwork with concrete. Lay the reinforcement and fill up with concrete. Trowel smooth.
9. When the concrete floor has set, remove the cover material and formwork. Build the formwork for the walls, allowing two openings in the rear wall, one for a vent pipe and the other for an overflow pipe (see Figure 44b). The vent pipe opening should be near the top corner of the wall.
10. Care should be taken to ensure that the reinforcement in the walls is maintained in the correct position. In addition, the formwork will need to be adequately braced. Coat the formwork with oil or grease.
11. When filling the formwork with concrete to make the walls, use a steel rod or stick to work between the reinforcing bars in order to prevent holes forming in the concrete.
12. Cover the top of the walls with wet straw or burlap and keep moist for 3 to 7 days.
13. Remove formwork after 7 days.
14. Fix the "T" fitting and overflow pipe in place with mortar. Install the elbow fitting and vent pipe.
15. Excavate the trench in a straight line, of slope 1 in 100, from the vault to the soakage pit.
16. Excavate the pit site.
17. Fill the space between the aqua privy vault and sides of the hole with soil without disturbing the overflow pipe.
18. Connect the overflow pipe with the seepage pit and backfill the trench.
19. Remove cover material and formwork from the slab. Set the slab over the vault after mortaring the drop pipe-line which should penetrate the water to a depth of 100 mm. Use tar or other material to keep the edges of the slab waterproof. Do not use mortar as the slab will have to be removed later for reuse.

Fig. 43. IMPROVED SEWERED AQUA PRIVY WITH SULLAGE DISPOSAL

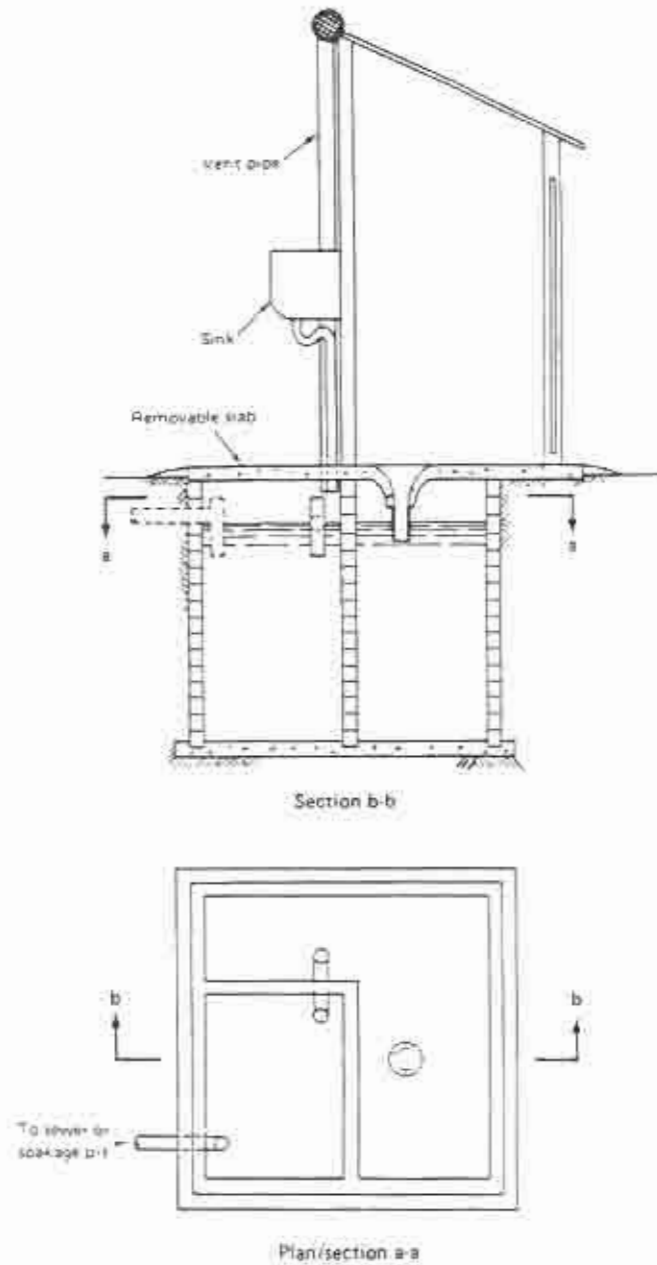

Sanitation Guidelines

Fig. 44. CONSTRUCTION DETAILS FOR AQUA PRIVY

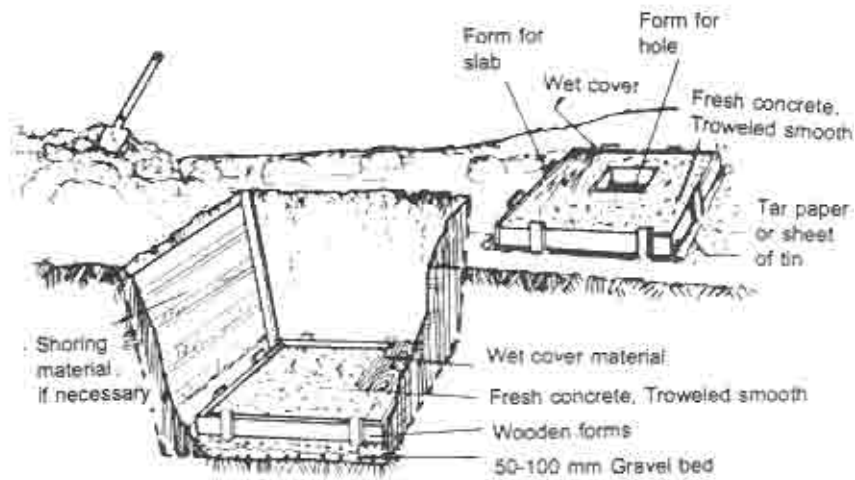

(a)

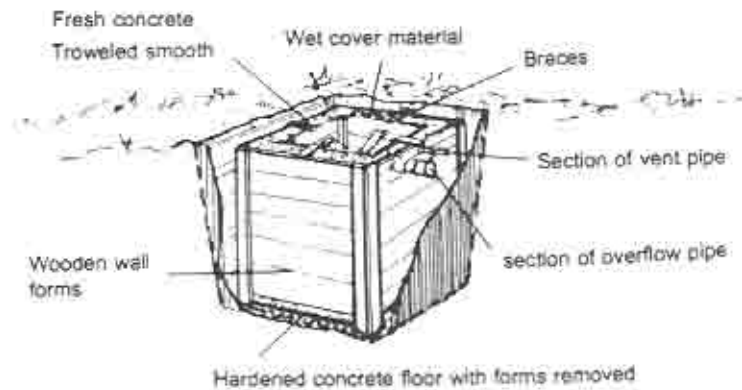

(b)

Sanitation Guidelines

20. Fill the vault with water up to flow line.
 21. Build a shelter around the privy slab according to local requirements.
 22. Attach the remaining sections of the vent pipe to the rear wall or roof of the shelter.
 23. Cover the seepage pit to prevent entry of insects or animals.
- A. For brick and mortar construction (Fig. 45)
1. Follow step 1 to 8 as above.
 2. After the concrete floor has set, remove the cover material and formwork. Use cement mortar of 1:3 mix to build the wall.
 3. When the rear wall reaches the flow-line height, fix a section of the overflow pipe in position using mortar. Fix a section of the vent pipe near the top of one corner of the rear wall, as shown in Figure 45. Fill the top course of bricks with mortar to keep the slab in position.
 4. Allow 1 to 3 days for the mortar to set.
 5. Plaster the inside of the vault with two coats of 10 mm cement mortar to make it watertight.
 6. Follow steps 15 to 23 described above.

Advantages and Disadvantages

Advantages:

1. If properly used and maintained, the aqua privy satisfies the previously cited sanitary requirements relating to health hazards and aesthetic considerations.
2. It is a relatively simple, permanent installation.
3. Correctly maintained there is no odour and no problems with fly or mosquito

Sanitation Guidelines

breeding.

4. It can be located near the dwelling.
5. It will not be clogged by bulky anal cleansing material.
6. If a community sewerage system is subsequently installed, the aqua privy tank may be connected directly with it. If aqua privies are common then small bore sewerage may be appropriate at lower cost than conventional sewerage.

Disadvantages

1. Its rather high initial cost may prevent its extensive use in rural areas.
2. It may not be successful in rural areas where there are no organized sanitation and health education services.
3. It requires water for its operation, although a small volume only will suffice.
4. It requires daily operation and maintenance.
5. It cannot be used in very cold climates, where the water seal would freeze.

2.2.3. Septic Tank

Description

The septic tank is the best of the water-carried excreta and liquid waste disposal systems. It is suitable for use in individual dwellings, small groups of houses, or institutions located in rural areas which are not connected to sewer systems. The septic tank consists of a covered settling tank into which the raw sewage is led by the building sewer (see Figures 46, 47 and 48). All liquid sullage wastes, including those from bathrooms and kitchens, may be sent to the septic tank without endangering its normal operation. The processes which take place inside the septic tank constitute the "primary treatment" of the raw sewage. Those processes which occur in the disposal field form the "secondary treatment".

Fig. 45. CONSTRUCTION DETAILS FOR BRICK VAULT OF AN AQUA PRIVY

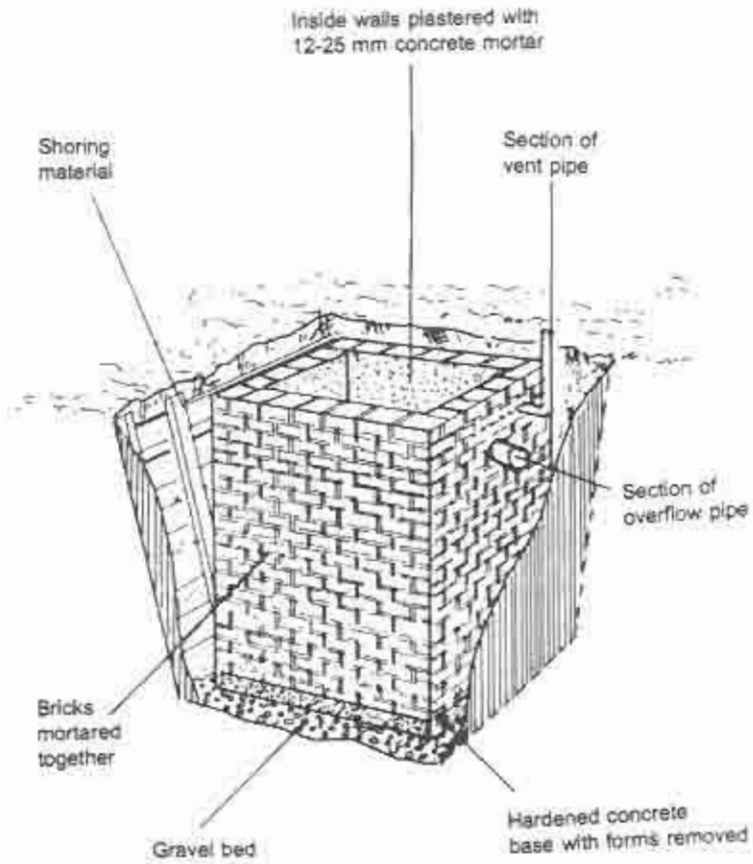

Sanitation Guidelines

Household septic tanks are usually designed in accordance with standards established by the appropriate government department. Larger systems such as those for hotels, schools or hospitals should be planned and designed by a senior technician or an engineer. Construction needs to be carefully supervised, especially of the seepage field, to ensure that effluent is uniformly distributed. Middle level technicians should understand the principles of operation and maintenance of septic tanks and be able to explain them to the public who may require advice, guidance and assistance in the installation of a household septic tank system.

Components and their Design

The Tank

(1) Function

Incoming sewage is held in the tank for a period of one to three days, according to the tank capacity. During this period the heavier solids settle to the bottom as sludge. Most of the lighter solids, including grease and fats, remain in the tank and form a scum over the water surface. Material that neither settles nor floats is carried away by the effluent into the final disposal system.

The solids retained in a septic tank undergo anaerobic decomposition through the activity of bacteria. This results in a considerable reduction in the volume of sludge, which allows the tank to operate for periods of one to four years or more, depending upon circumstances, before it needs to be cleaned.

The effluent of a properly designed and efficient septic tank is slightly turbid due to finely divided solids in suspension. However, it is still offensive in character; on standing, it yields little sediment but has a characteristic, putrid odour. In addition, the effluent is potentially dangerous to health, as it may contain pathogenic bacteria, cysts, and worm eggs which pass unharmed through the tank during the relatively short retention period.

As the sludge decomposes the gas produced rises to the surface as bubbles. These carry with them particles of decomposing sludge which inoculate incoming sewage with some of the organisms which decompose organic matter. The bubbling of gas through the liquid interferes to a certain extent with the normal sedimentation of sewage solids. This interference may be minimized by the addition of a second

Sanitation Guidelines

compartment to the septic tank. The lighter, suspended solids carried from the first compartment find quieter conditions for settling in the succeeding compartment. This is especially valuable at times of rapid anaerobic decomposition when sludge solids are found in greater quantity in the tank's first compartment. The sludge in the succeeding compartment is usually more homogenous and flocculent than that in the first compartment, and there is also less scum production. The effluent of such a tank will contain a lower proportion of suspended matter than that from a single-compartment system. A two-compartment septic tank is now generally preferred to one with a single-compartment.

For the efficient development of the biological processes, turbulence should be avoided, and the disturbing effects of surge flows should be reduced to a minimum. Turbulence and surge flows may be so serious in small or overloaded tanks as to cause a complete breakdown of tank operation on secondary-treatment processes. The space available for clarification in larger tanks has a certain compensatory or equalizing effect.

In order to ensure and speed-up the onset of biological processes, newly constructed septic tanks are usually seeded with a quantity of sludge taken from another tank already in operation. This sludge, which is in an advanced state of decomposition, provides the bacteria necessary for the biological process which follows the initial breakdown of raw organic matter by anaerobic bacteria.

(2) Size of tank

The principal factors to be considered in deciding on the capacity of a septic tank are:

- (a) the average daily flow of sewage;
- (b) the retention period, from 1-3 days, usually 24 hours;
- (c) adequate sludge storage, for desludging every 2-3 years.

Fig. 46. TYPICAL LAYOUT OF SEPTIC TANK SYSTEM

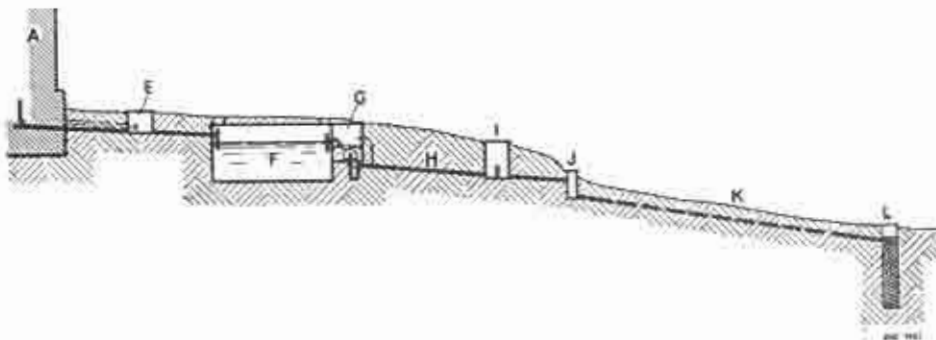
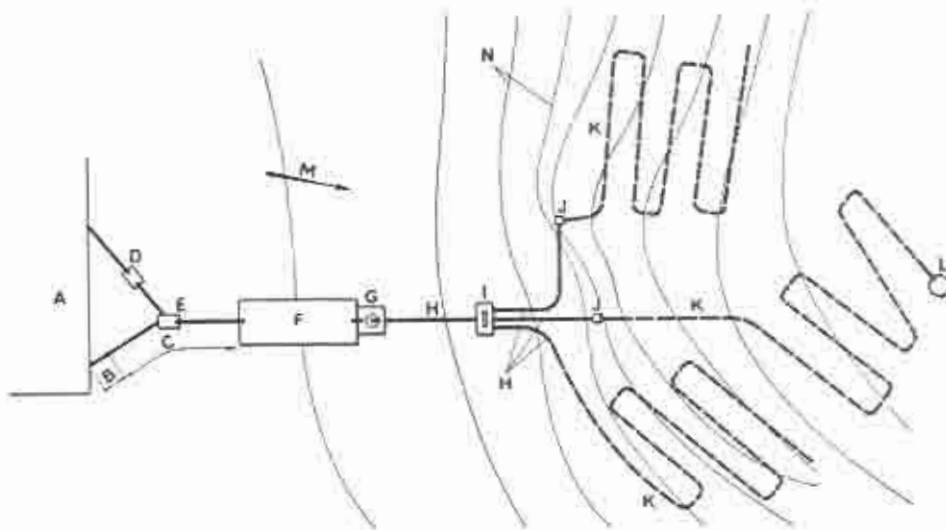

- A = Private house or public institution
- B = House sewer
- C = Building sewer
- D = Grease Interceptor on pipe line from kitchen
- E = Manhole
- F = Septic tank
- G = Dosing chamber and siphon

- H = Pipes laid with tight joints
- I = Distribution box
- J = Drop-boxes or terracotta L's
- K = Absorption tile lines
- L = Seepage pit, when required
- M = Slope of ground surface
- N = Topographic contour lines

Fig. 47. TYPICAL HOUSEHOLD SEPTIC TANK

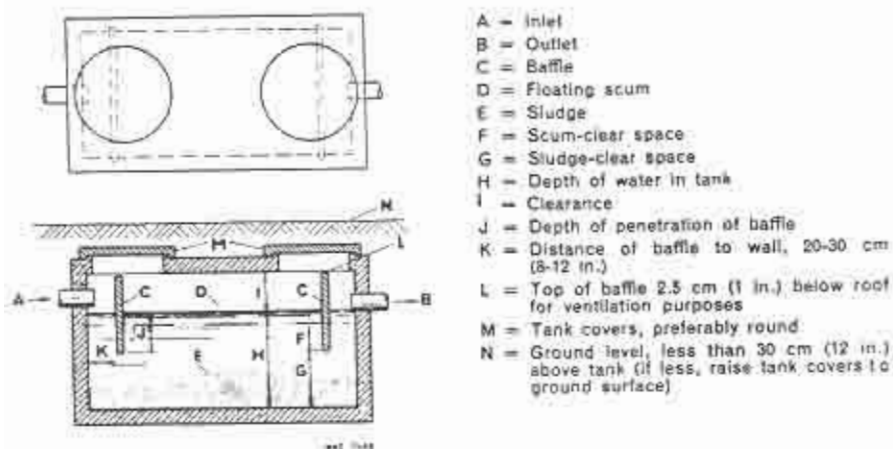

The average daily flow of sewage depends on the average water consumption in the area under consideration. In rural areas and small communities the water consumption per person is usually lower than in urban areas. Sewage flows of less than 100 litres per person per day may be expected in most rural areas of the world. However, experience indicates that such low figures cannot be used for the design of septic tanks since they are seldom cleaned before trouble develops. It is therefore important that their capacity be large enough to permit reasonably long periods of trouble-free service and to prevent frequent and progressive damage to the effluent absorption systems due to discharge of sludge by the tanks. For this reason the capacity of residential, single-chambered, septic tanks should be at least 1900 litres.

Fig. 48. SEPTIC TANK WITH TWO COMPARTMENTS AND DOSING CHAMBER

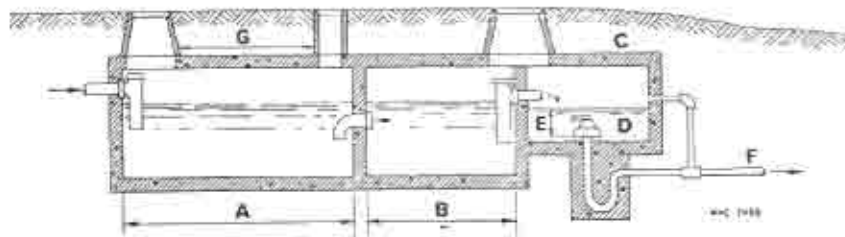

- | | |
|--|-----------------------------|
| A = Inlet compartment | D = Dosing siphon |
| B = Outlet compartment | E = Drawing depth of liquid |
| C = Dosing chamber | F = Discharge pipe |
| G = Manhole covers (raised when earth cover greater than 30 cm (12 in.)) | |

Another method of calculation is based on the estimation of the sludge accumulation rate, which is usually between 0.03 and 0.04 cubic metres per person per year. The time interval between desludging operations is usually taken as two or three years. An example for a septic tank, serving 10 persons, is as follows: the sludge accumulation rate will be $10 \times 0.04 = 0.4$ cubic metres per year. For 3 years, it will amount to: $3 \times 0.4 = 1.2$ cubic metres. Since a septic tank must be cleaned when the volume of sludge reaches one-third of the tank's liquid capacity, the liquid volume of the tank should be $1.2 \times 3 = 3.6$ cubic metres, or 3600 litres. This figure compares favorably with the corresponding figure shown in Table 3 (i.e. 3420 litres).

The design of septic tanks for schools, rural hospitals or other public institutions may provide for a retention period of less than 24 hours, when the effluent discharges into a sewer. In these circumstances it is expected that the septic tanks will receive regular inspection and maintenance, including more frequent cleaning than individual household septic tanks.

Table 3. REQUIRED CAPACITIES AND DIMENSIONS OF SEPTIC TANKS SERVING INDIVIDUAL HOUSEHOLDS

| Number of people served | Liquid capacity of tanks Litres | Recommended Dimensions - m | | | |
|-------------------------|------------------------------------|----------------------------|--------|--------------|---------------------------------|
| | | Width | Length | Liquid depth | Total depth of tanks dimensions |
| 4 | 2200 | 0.90 | 1.80 | 1.20 | 1.50 |
| 6 | 2300 | 0.90 | 2.13 | 1.20 | 1.50 |
| 8 | 2900 | 1.07 | 2.26 | 1.20 | 1.50 |
| 10 | 3420 | 1.07 | 2.34 | 1.37 | 1.67 |
| 12 | 4200 | 1.20 | 2.55 | 1.37 | 1.67 |
| 14 | 4920 | 1.20 | 3.00 | 1.37 | 1.67 |
| 16 | 5700 | 1.37 | 3.04 | 1.37 | 1.67 |

The total tank depth is equal to liquid depth plus 30 cm height of free space above water line up to the cover of the tank.

The capacities indicated in Table 3 should, in most countries, provide sufficient sludge storage space for a period of two years or more, and an additional volume equal to the sewage flow for 24 hours.

The invert of the inlet pipe should be 7.5 cm above water level. Connections between two compartments are best made by means of a pipe (ell) whose lower end does not penetrate into the liquid at a depth lower than the outlet device, as shown in figure 48.

(3) Shape of tank

The shape of the tank influences the velocity of flow through it, the depth of accumulation of sludge and the presence or absence of stagnant corners. If the tank is too deep, the other dimensions will be small and a direct current from inlet to outlet will occur, greatly shortening the retention period.

If the tank is too shallow the sludge-clear space will be too small, and the effective cross-section of the tank will be reduced. When the width is too great, there will

Sanitation Guidelines

be dead pockets of appreciable size at the corners where little, if any water movement takes place. Finally, if the tank is too narrow, the velocity of flow will be so great as to interfere with efficient sedimentation.

In a tank comprising two equally-sized compartments, there is no difference in performance between rectangular and cylindrical shapes, if equal solids storage capacities are provided. Rectangular tanks should be designed with a length not less than two, but nor more than three, times the width. The liquid depth should not be less than 1 metre, but not more than 1.8 metres in large tanks. Clearance above the water level is usually 30 cm.

(4) Location of tank

The septic tank should be located to permit easy drainage from the dwelling and to the effluent disposal system. The location of the tank should ensure that sufficient area is available for disposal of the effluent and that tile lines may be laid on a gentle slope at a depth not exceeding 75 cm at any point.

Table 3, for the design of septic tank capacities, is based on the determination of the average daily flow of sewage from dwellings. Such a determination is not always easy to make and must be estimated from local observations and experience, and given a large safety factor.

(5) Inlet and outlet arrangements

Various inlet and outlet arrangements have been used in septic tanks. The baffle arrangements, shown in Figures 47 and 48, have been found to be preferable to the "sanitary T" which may become clogged by paper or other debris. The inlet baffle or tee should extend 30 cm below water level. The outlet baffle should penetrate below the surface to a depth of 40 per cent of the liquid depth.

Both devices should permit free ventilation through the tank and through inlet and outlet pipes. These should extend at least 15 cm above the water line and leave at least 2.5 cm clearance below the tank's cover for ventilation purposes. Baffles are usually placed 20-30 cm away from the inlet and outlet pipes, whose ends are flush with the walls of the tank.

Sanitation Guidelines

Since periodic inspections are necessary, the tank should not be buried more than 30–45 cm below ground level. Inspection covers should be extended to reach ground level. Precautions should be taken to prevent surface run-off entering the tank.

Because of the possibility of leakage, especially around the inlet and outlet pipes, the tank should be located downhill and at least 15 metres from wells and other sources of water supply. In addition, septic tanks and drainfields should be located at least 1.5 metres from buildings, 3 metres from large trees or water pipes, and 7.5 metres from streams.

The Building Sewer and the Vent Pipe

The building sewer is that part of the horizontal piping of a building drainage system which carries the liquid wastes from the house to the septic tank. It should be constructed of cast iron, vitrified clay, concrete, asbestos cement or plastic pipe. Joints should be watertight to prevent leakage and to prevent damage by or blocking by tree roots.

The points to be observed in the construction of the building sewer are as follows:

- (1) Minimum pipe diameter of 15 cm if sewer is of vitrified clay or concrete, and 10 cm, if sewer is of cast iron, asbestos cement or plastic.
- (2) Minimum gradient of 1 per cent, but 2 per cent is preferable.
- (3) Cleanout at every change in line of 45° or more. Bends of 90° should be avoided wherever possible. Cleanouts are desirable within 1.50 m of the septic tank where tanks are located more than 6 m from the building. An inexpensive cleanout can be made by inserting a tee in the line with the vertical leg extending to ground level and plugged with a cap. Inspection chambers may be constructed as an alternative to cleanouts.
- (4) All joints made watertight and protected from damage by roots wherever necessary.

Sanitation Guidelines

The gases produced in household tanks usually flow back through the building sewer into the vent pipe of the domestic plumbing system. Where there is no domestic vent pipe, or where the septic tank is located far from the house, the tank itself must be provided with a vent pipe capped with a plastic screen (18 mesh size). Deflectors are sometimes installed in the tank's second compartment in order to stop the gases escaping through the septic tank outlet pipe into the effluent disposal system..

The Disposal of Effluent

The secondary treatment of septic-tank effluent is based on the oxidation of organic matter through the activity of aerobic bacteria. These thrive in the upper layers of the soil and in sand or stone beds whose pores are naturally aerated by oxygen from the air. The effluent is spread as uniformly as possible over the grains of soil or sand, or over small stones. A biological slime develops in which the aerobic bacteria and microorganisms are active. It is important that this biological slime should not be overloaded or submerged for any great length of time; otherwise, the aerobic bacteria will die and anaerobic conditions will develop. In large installations, aeration is achieved by intermittent dosing with a dosing siphon installed next to the septic tank. In this way, the soil or sand bed recuperates, and air penetrates into the spaces between soil or sand particles during the intervals between flushes of the siphon. Natural aeration of the soil is facilitated in filter trenches through the drain pipes and sometimes through a vent pipe or seepage pit installed at the lower end of the disposal field.

Ventilation of the soil or sand medium may stop if the pores are allowed to become clogged by suspended matter carried by the effluent or by excessive slime growths. In either case, the trouble may be traced to defective or inefficient operation of the septic tank itself, although excessive slime growth may also be due to overloading of the disposal field.

The effluent from the septic tanks should never be permitted to run into canals, open ditches or small fishponds, or be used for irrigation of crops without adequate treatment and the permission of local health authorities. Only three of the more common and simple methods of effluent disposal are presented in these guidelines: the seepage pit (or leaching pit), subsurface irrigation (or drainfield), and sand filters.

Sanitation Guidelines

(1) Seepage pit

The seepage pit receives the effluent from aqua privies, cesspools or septic tanks and allows it to percolate away into the ground. It can also be used for the disposal of laundry, bathroom, and kitchen wastewater. The seepage pit can be built at the lower ends of subsurface disposal tile lines in order to catch the septic-tank effluent which may have gone through without percolating away.

Fig. 49. SEEPAGE PIT

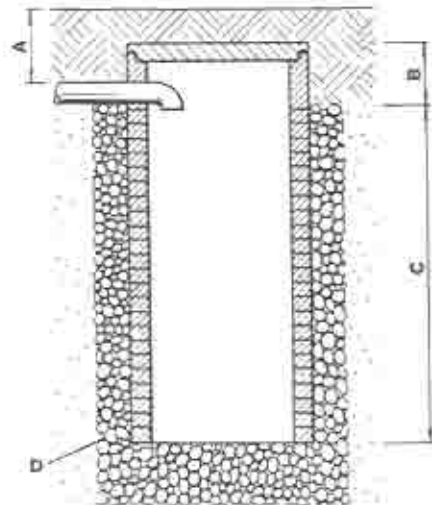

- A - Variable depth of soil
- B - Cement joints
- C - Open joints
- D - Rock fill, 15 cm (6 in.) or more

As shown in Figure 49, the seepage pit consists of a round hole in the ground dug sufficiently deep so as to penetrate a minimum of 1.8 metres into a porous layer of the earth. Diameters of between 1.0 to 2.5 metres and depths of 2 to 5 metres are common.

Sanitation Guidelines

The walls are lined with bricks or stones laid without mortar below the level of the inlet pipe. Alternatively, the hole may be filled with stones, in which case a lining is not required. The seepage pit should be tightly covered to prevent the entry of surface water, mosquitoes and flies.

If the soil in which the pit has been dug is not sufficiently porous, the effluent will slowly accumulate and will ultimately overflow.

Even in porous soils such a situation is common. The pores of the earth walls become choked by the deposit of finely divided matter carried by the effluent and by solids built up by organisms which thrive on grains of soil in contact with the effluent. These factors influence the life span of a seepage pit. A pit should normally last for perhaps 6-10 years if the effluent is only slightly turbid as a result of efficient primary treatment of the raw sewage.

When a seepage pit stops operating, a new one should be dug several meters away. In order to increase the life span of the disposal system, it is possible to dig two or three seepage pits and to connect them at the top. The distance between any two pits should be not less than the diameter of the larger pit.

The obvious disadvantage of seepage pits is the danger of groundwater pollution. They should be located downhill and at least 15 metres from drinking water sources and wells. The construction of seepage pits is not usually permitted by health authorities in built-up areas where groundwater is used for domestic purposes.

(2) Subsurface irrigation

This is the method most often employed with small septic tanks serving households and institutions. Tank effluent is dispersed into the top layer of the ground by means of open-jointed drain pipes laid in covered trenches. The effluent is purified through the action of the aerobic saprophytic soil bacteria, after which it drains away into the ground. This method cannot be used where the subsoil is not porous, where the groundwater table rises to within 1.2 metres of the ground surface, or where there is a danger of polluting water supplies (eg. in fissured limestone formations). In particular, it is not applicable in impervious clay soils and swampy lands.

Sanitation Guidelines

Percolation Tests

In order to calculate the length of pipe required in the disposal field, it is necessary to determine the degree of permeability of the soil by making percolation tests. The following percolation test is suggested:

1. Number and location of tests.- Six or more tests shall be made in separate test holes uniformly spaced over the proposed absorption field site.
2. Type of test hole. - Dig or bore a hole, with a diameter of between 10 - 30 cm and vertical sides, to the depth of the proposed absorption trench. In order to save time, labour, and volume of water required per test, the holes can be bored with a 10 cm auger.
3. Preparation of test hole. - Carefully scratch the bottom and sides of the hole with a knife blade or sharp pointed instrument, in order to remove any smeared soil surfaces and to provide a natural soil interface into which water may percolate. Remove all loose material from the hole. Add 5 cm of coarse sand or fine gravel to protect the bottom from scouring and sediment.
4. Saturation and swelling of the soil. - Carefully fill the hole with clear water to a minimum depth of 30 cm over the gravel. By refilling if necessary, or by supplying a surplus reservoir of water, such as an automatic siphon, keep water in the hole for at least 4 hours and preferably overnight in order that the soil swells. This saturation procedure ensures that the soil approaches the condition it will be in during the wettest season of the year. Thus, the test will give comparable results in the same soil whether made in a dry or a wet season.

In sandy soils containing little or no clay, the swelling procedure is not essential and the test may be made as described under item 5C below, after the water from one filling of the hole has completely seeped away.

5. Percolation rate measurement.- With the exception of sandy soils, percolation rate measurements shall be made on the day following the procedure described in item 4, above.

A. If water remains in the test hole after the overnight swelling period, adjust the depth to approximately 15 cm over the gravel. From a fixed reference point, measure

Sanitation Guidelines

the drop in water level over a 30 minute period. This drop is used to calculate the percolation rate.

B. If no water remains in the hole after the overnight swelling period, add clear water to bring the depth of water in the hole to approximately 15 cm over the gravel. From a fixed reference point, measure the drop in water level at approximately 30 minutes intervals for 4 hours, refilling 15 cm over the gravel as necessary. The drops measured will provide information for possible modification of the procedure to suit local circumstances.

C. In sandy soils (or other soils in which the first 15 cm of water seeps away in less than 30 minutes, after the overnight swelling period) the time interval between measurements will be 10 minutes and the test run for 1 hour. The drop that occurs during the final 10 minutes is used to calculate the percolation rate.

6. The percolation rates in Table 4 are listed in units of the time required for the water level in the test hole to drop 2.5 cm. A calculation is required to convert the measured values into the appropriate unit. The length of time of the test (30 minutes in A and B above, and 10 minutes in C) is divided by the distance in centimetres that the water level drops and the result is multiplied by 2.5. For example, the water level in a test hole dug in silty loam soil drops 7.5 cm in 30 minutes. The percolation rate will be $30/7.5 \times 2.5 = 10$ minutes.

The effective absorption area required may then be found in Table 4: (see next page).

A percolation rate of 60 or more is an indication that the soil is unsuitable for effluent disposal by subsurface irrigation. In such a case, the options may be considered of constructing seepage pits which penetrate into a deeper, permeable layer of ground or use of sand filter trenches.

Effective absorption area means the flat area in the bottom (only) of trenches. The figures in Table 4 are based on a daily flow of 190 litres of sewage per person. In many parts of the world, the daily flow of sewage will be substantially less than this, in which case the figures in Table 4 may be reduced on the basis of field experience.

Table 4. ABSORPTION AREA REQUIREMENTS FOR RESIDENCES AND SCHOOLS

| Percolation rate (time required for water to fall 2.5 cm in minutes) | Required effective absorption area (square meters of absorption trench bottom per person served) | |
|---|---|---------|
| | Residences | Schools |
| 2 or less | 2.30 | 0.84 |
| 3 | 2.80 | 0.93 |
| 4 | 3.25 | 1.12 |
| 5 | 3.50 | 1.21 |
| 10 | 4.65 | 1.67 |
| 15 | 5.35 | 1.86 |
| 30 | 7.00 | 2.70 |
| 45 | 8.45 | 3.10 |
| 60 | 9.30 | 3.50 |
| over 60 | Unsuitable for shallow absorption system | |

Drainfield

Plain-end tile pipes, 10 cm in diameter and 30 - 60 cm in length, are commonly used (see Figure 51). Bell and spigot sewer pipe of the same diameter and of maximum length 60 cm may be preferred. A small stone or cement fillet may be used in the bottom of each socket joint to centre the spigot in the bell. Plain-end tiles need a firm support to remain on an even grade to enable uniform distribution of the septic-tank effluent. Such a support is provided by means of a flat board, eg. 2.5 x 10 cm in size - which is set on edge and nailed to stakes driven at intervals in the bottom of the trench. The top of the board can be laid accurately to the desired grade (see Figure 50).

Both plain-end tile pipes and Bell and spigot pipe are laid in such a way as to leave an open space of 0.6 to 1.2 cm between pipe lengths for the effluent to run out. When plain-end pipes are used, the upper half of the joint must be covered with a strip of asphalt or tar paper to prevent entrance of fine sand and silt which might interfere with the flow of effluent. Bell and spigot pipes do not require this protection, since the joints are protected by the bell ends. In both cases the joints should be covered with at least 5 cm of gravel.

Fig. 50. ABSORPTION TRENCHES

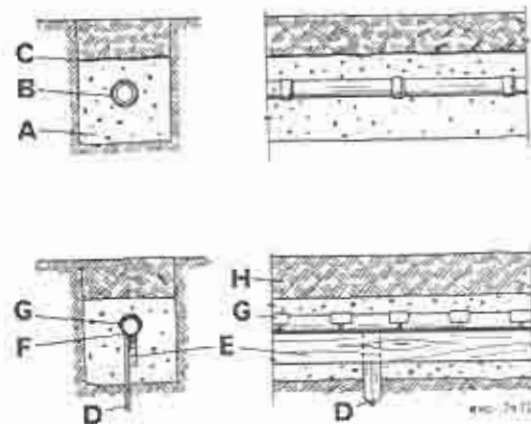

- A = Coarse gravel surrounding pipe
- B = Bell and spigot pipe
- C = Building or tar paper
- D = Wooden stakes supporting grade board E
- E = Longitudinal boards, nailed to stakes and laid at exact grade selected for absorption lines
- F = Absorption tile pipes resting over grade boards
- G = Tar paper covering upper half of open joints
- H = Earth-tamped backfill

The depth of pipe-inverts should be between 30 cm and 75 cm. An earth cover of about 30 cm will protect the pipe against damage. Under roads or paths used by heavy agricultural machines, it may be necessary to use cast-iron pipes or strong vitrified sewer-pipes, laid with tight joints, in order to maintain line and grade.

The gradient of the disposal pipelines should not be too small or too great: if too flat, only the upper area of the disposal field will receive the effluent; if too steep, there will be a rush of liquid down to the lower portion of the disposal field, which will soon become waterlogged. The optimum slope is between 0.16 and 0.32 per cent, and should not exceed 0.5 per cent. In order to maintain such grades on steep-sloping land, disposal pipes should be laid along the contours of the ground, and changes of direction should be made by means of drop-boxes or terracotta L's laid with cemented joints. At such points special precautions should be taken to cut off the underground flow of sewage which is normally running above the upstream

Sanitation Guidelines

trench bottom since it may cause erosion of the ground around the drop-boxes and terracotta Ls. This may be done by filling with well-tamped clay soil the last 30 cm of trench preceding each drop-box or L-pipe.

Fig. 51. TYPES OF DISTRIBUTION BOX

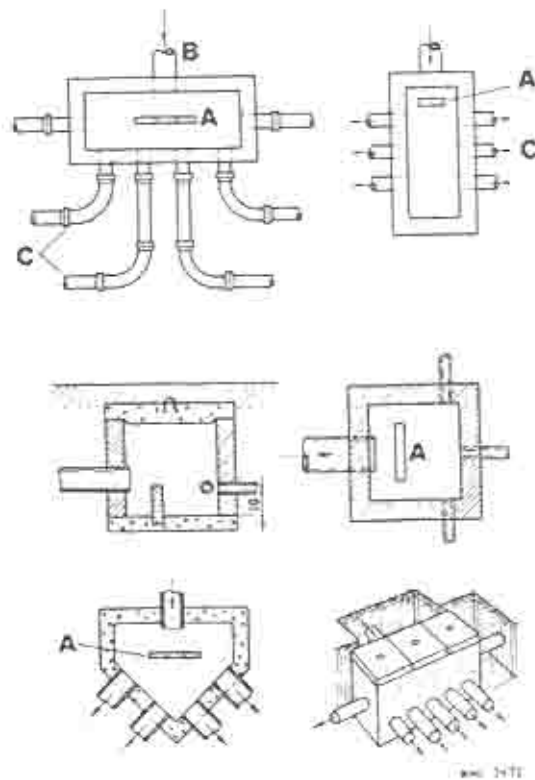

- A = Baffle in wood or brick
- B = Inlet from septic tank or dosing chamber
- C = Outlet to absorption lines

Sanitation Guidelines

The size and lengths of trenches required should be calculated on the basis of the effective absorption area. The size and minimum spacings recommended may be obtained from Table 5.

Table 5. SIZE AND MINIMUM SPACING REQUIREMENTS FOR DISPOSAL TRENCHES

| Width of trench at bottom (m) | Depth of Trench (m) | Effective absorption area (m ²) | Spacing of lines* (m) |
|-------------------------------|---------------------|---|-----------------------|
| 0.45 | 0.45 to 0.75 | 0.47 | 1.80 |
| 0.60 | 0.45 to 0.75 | 0.61 | 1.80 |
| 0.75 | 0.45 to 0.90 | 0.76 | 2.30 |
| 0.90 | 0.60 to 0.90 | 0.94 | 2.75 |

* A greater spacing is desirable where available area permits

Trenches should not exceed 30 metres in length; otherwise, the effluent will not be evenly distributed over the disposal field. The smallest household disposal system consists of two trenches 45 cm wide at the bottom and 30 metres long. So far as possible, trenches should be laid along straight lines. After the trenches are dug to the required size and depth a layer of at least 15 cm of filter material is placed over the bottom.

The pipes are then laid to the required gradient and surrounded by more filter material, which should be at least 5 cm thick above the top of the pipe. The rest of the trench is then backfilled with earth. The filter material may be washed gravel, crushed stone, slag, or clean clinker ranging in size from 1 cm to 6 cm, although one single size is sometimes preferred.

Surface run-off should be diverted away from the disposal field in order to avoid waterlogging of the soil, especially during heavy rains.

Trenches should be laid at least 7.5 metres away from large trees to avoid blockage due to the penetration of roots into the pipes. For the same reason, the land area above the disposal field should not be cultivated, but may be planted with short-rooted grass.

Sanitation Guidelines

Depending upon the layout of the trenches, it is good practice to build one or more seepage pits at the lower ends of the absorption lines. This serves to catch excess effluent and to ventilate the trenches through the piping system. The last 1.5 metres of trench preceding the seepage pit should be filled with well-tamped clay soil in order to stop the flow of sewage above the trench bottom and to prevent erosion.

Distribution Box

A distribution box is a chamber which insures an even distribution of the effluent to the subsurface disposal field through the drain pipes (see Figure 51). If easily accessible, it may also serve as an inspection manhole for checking the amount of suspended matter in the effluent from the septic tank as well as the proper distribution of effluent. It requires careful design and construction. Occasional inspection and maintenance are required to ensure efficient operation i.e., the equal distribution of flow among its various outlets. If a septic tank needs cleaning an outlet may become partially obstructed by floating matter or by other solid matter (twigs, small stones, etc.), which may accidentally fall through the manhole. As a result, a portion of the disposal field may become inoperative and the rest overloaded, becoming "sewage sick" within a short time.

The general practice followed in the design of distribution boxes may be described as follows:

The inlet pipe should enter at one end of the box about 5cm above the bottom. Sides of the box should extend approximately 30cm above the invert of the inlet pipe and the box should be provided with a removable cover. Since frequent inspection is not necessary, the cover of the box may be placed 30 to 45 cm below the surface of the ground. The inverts of drainage lines should be set within the lower 3 cm of the box and all must be at the same elevation. They should run straight in the desired direction; horizontal bends should be avoided where possible. When necessary, however drainage pipes of different diameters may be used under the same head, pipes all of the same size are more likely to receive an equal flow.

The box need not be more than 45 cm in width, nor longer than is necessary to accommodate drains for effective outlet capacity. Diversion baffle boards should not be installed in distribution boxes on systems serving individual dwellings. However, such construction may prove advisable on systems serving public buildings where constant supervision and maintenance are provided and where lines may be shut off

Sanitation Guidelines

for repairs or to rest the field when it becomes waterlogged. Flow diversion devices may be installed in a properly designed distribution box to facilitate rotation of use of the distribution lines where adequate and proper maintenance is assured.

Sand Filters

Sand-filter trenches may be built in soils which are tight and impervious (clayey soils) and which have a percolation factor exceeding 60. They may also be installed in places where groundwater occasionally rises and reaches a level 90 cm below the ground surface, or when insufficient area is available for subsurface irrigation.

As shown in Figure 52, a sand filter trench is wider than a regular absorption trench and includes:

- (1) an effluent distributing pipe, usually 10 cm in diameter;
- (2) a sand-filter bed not less than 60 cm deep, preferably 75 cm, through which the septic tank effluent trickles and undergoes biological filtration;
- (3) an underdrain, also 10 cm, in diameter, surrounded by a layer of gravel laid in the bottom of the trench. This underdrain receives the filtered effluent and discharges it into a ditch or similar watercourse. It also prevents groundwater from interfering with the biological processes taking place in the sand bed.

Much depends upon the porosity of the soil, fine-grained sand being best in terms of both permeability and ventilation. Impervious soils, such as clay, are totally inappropriate. Where groundwater is very close to the surface, it may not be possible to dispose of the effluent into the soil, since the pores of the soil above the water table are clogged with water held by capillary action. Experience shows that tile pipes should not be laid closer than 90 cm above the groundwater level.

Special care must be taken to ensure that the effluent-distributing pipes are laid on a uniform gradient. If grade boards are not used, the sand bed should be flooded to ensure thorough settlement before the distribution pipes are laid.

Clean, coarse sand should be used as filtering material, because fine sand will quickly clog and lead to failure of the system.

Sanitation Guidelines

The distribution piping and underdrains may be built of the same pipes that are used for the construction of the standard absorption trenches already described, i.e., plain-end tile pipes or bell and spigot sewer pipes. Long, perforated pipes have the advantage of maintaining the desired gradient, and may be preferred for distributing septic-tank effluent over the sand bed. The slope of the effluent distribution pipes may be the same as that previously mentioned for standard absorption trenches. However, the slope of underdrains may be as much as 1 per cent.

The loading rate for sand-filter trenches is estimated at about 38 litres per day per square metre of filter surface.

Sand-filter trenches usually produce a highly purified effluent which may be disposed of in open ditches or streams. There is, however, no certainty that the filtered effluent is bacteriologically safe and it should not be discharged into a water source which is abstracted for drinking. Sand-filter trenches should never be constructed without the prior approval of the local health department.

Sub-surface Sand Filters

Sub-surface sand filters operate under the same principles as sand filter trenches. They constitute a maximal artificial development of the filtering capacity of the subsurface (soil). The area required for filtration is dug up to the required depth. Underdrains are placed and covered with at least 5 cm of coarse gravel or crushed stone and the area is filled with 75 cm of coarse sand. A 10 cm layer of coarse gravel or crushed stone is placed over the sand and the effluent distribution pipes are laid on this, as shown in Figure 53. The area is then covered with soil and sloped to divert rainwater away from the filter area. The loading rate for subsurface sand filters is 35 to 40 litres per square metre of filter per day. The effluent is usually of good chemical and physical quality but will contain many bacteria.

For large installations, subsurface sand-filters are likely to be cheaper than filter trenches and should be selected when dosing siphons are installed. Siphons have the advantage of ensuring adequate dosage and of providing a long rest-period for the filter sand. Dosing tanks equipped with single siphons should be installed where the total filter area exceeds 17 square metres and where the length of distribution pipes exceeds 90 metres. When the length of these pipes is greater than 250 metres the filter bed should be divided into two or more sections and dosed separately by alternating siphons. Lining of the bed (or beds) is not necessary except in very wet, soft soil.

Sanitation Guidelines

Fig. 52. SAND FILTER TRENCH

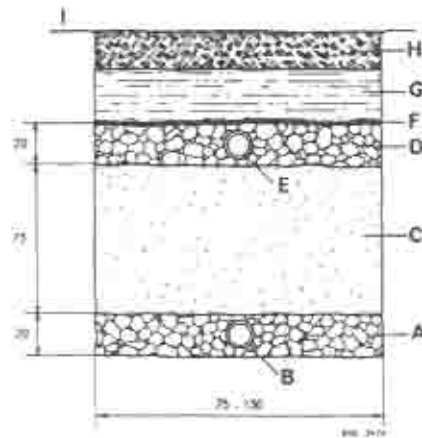

- A = Coarse gravel or crushed stone
- B = Underdrain for collection of filtered effluent
- C = Coarse filter sand
- D = Coarse gravel or crushed stone
- E = Effluent distributing pipe, made of tiles or of perforated long pipes
- F = Building or tar paper
- G = Backfill, tamped in moist layers 15 cm (6 in.) thick
- H = Top soil
- I = Original ground-level

Measurements shown are in centimetres

Subsurface sand filters, like sand-filter trenches, may be built in most rural areas of the world. They require little attention. However, since they cannot be maintained, they eventually become clogged and must be rebuilt.

Sanitation Guidelines

Fig. 53. SUBSURFACE SAND FILTER

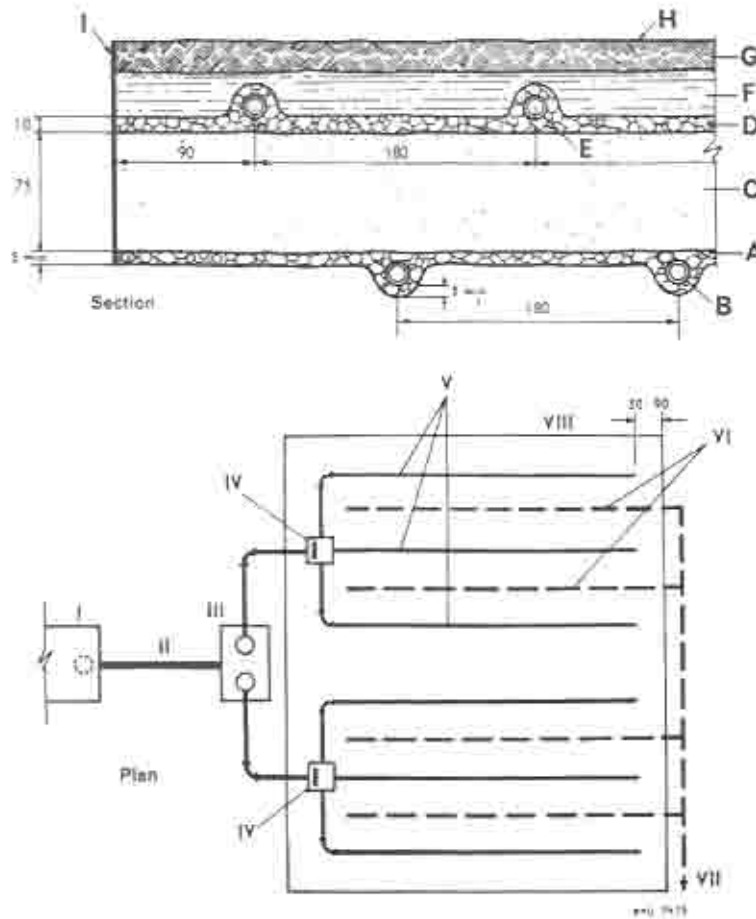

Section:

- A = Coarse gravel or crushed stone
- B = Underdrain for collection of filtered effluent
- C = Coarse filter sand
- D = Coarse gravel or crushed stone
- E = Effluent distributing pipes made of tiles or of perforated pipes
- F = Backfill, tamped in moist layers 15 cm (6 in.) thick
- G = Top soil
- H = Original ground-level
- I = End line of subsurface filter

Plan:

- I = Septic tank
- II = Discharge line
- III = Siphon chamber
- IV = Distribution boxes
- V = Effluent distributing pipes (= E in section)
- VI = Underdrain for collection of filtered effluent (= B in section)
- VII = Collection pipe to final point
- VIII = Limits of subsurface filter

Open Sand Filters

In areas where groundwater remains permanently close to the ground surface, or where subsoil conditions are unfavourable (e.g., rock formations) for the construction of the disposal systems already described, open sand filters may be considered. These filters are built above or partly below ground depending on local conditions. In both cases masonry or concrete walls are needed to support the sides and to retain the sand. Earth embankments may also be used.

In open sand filters, purification of the septic-tank effluent is due to the action of aerobic bacteria in the interstices of the sand bed and to mechanical straining. Since these bacteria require oxygen in order to survive, the filters are usually operated intermittently so that air is drawn into the filter bed during the intervals between dosing. For this reason, these filters are frequently referred to as intermittent sand filters. If properly constructed and operated, open sand filters produce an effluent of high and stable quality.

Open sand filters are usually divided into two or more compartments in order to facilitate regular cleaning of the beds and to regulate operation (see Figure 54). A bed of clean coarse sand 75 to 105 cm thick, underlaid with gravel is used. Sand possessing an effective size of 0.2 to 0.4 mm and a uniformity coefficient of 4.0 will give satisfactory performance. Effective size (D_{10}) is determined from a sieve analysis of a sample of the sand; 10 per cent by weight of the sample is finer and 90 per cent by weight is coarser than the effective size. A sieve analysis is also used to determine the uniformity coefficient, by determining D_{60} (60 per cent by weight of the material is finer and 40 per cent by weight is coarser) and dividing it by D_{10} , the effective size.

In small installations, the underdrainage system and effluent distribution pipes may be arranged as shown in Figure 54. The larger systems are built and operated on the principles of municipal sand filters.

Loading rates for open sand filters are greater than those allowed for subsurface sand filters and depend upon the degree of treatment achieved in the septic tanks, the size of the sand particles used, and the temperature. Loading rates applicable in warm climates are higher than those in temperate and northern countries. As an example, the loading rates on open sand filters with uniformity coefficients not exceeding 4.0, as recommended for application in the USA, are shown in Table 6, in litres per square metre per day:

Sanitation Guidelines

Table 6. LOADING RATE ON OPEN SAND FILTERS

| Region | Loading rate, litres per m ² per day | | | | |
|--------------|---|---------|---------|---------|---------|
| | Effective size of sand | | | | |
| | 0.2mm | 0.3mm | 0.4mm | 0.5mm | 0.6mm |
| Southern USA | 378 000 | 493 000 | 606 000 | 682 000 | 756 000 |
| Northern USA | 300 000 | 378 000 | 455 000 | 530 000 | 606 000 |

The intermittent operation of open sand filter beds is usually achieved by use of dosing siphons. Depending on the volume of sewage to be treated, these siphons are operated in such a manner as to supply one or more doses per day or a single dose in several days. Most commonly one to four doses per day are provided, the bed being covered each time to a depth of 5 to 8 cm. The best practice calls for the installation in the same chamber of two siphons operating alternately and discharging upon different beds.

Open sand filters need not usually be covered. However, in order to prevent odours and nuisances occurring when operation is deficient, it may be advisable to cover the sand beds with a 15 cm layer of earth.

The great disadvantage of these filters is that they require considerable attention. Constant maintenance and cleaning of the sand surface are required; otherwise, the ventilation of the beds is interrupted, and the nitrifying bacteria die away. Cleaning is done by raking the beds and, when necessary, by removing the top 2.5 cm of dirty sand. This sand is washed and returned to the bed in order to maintain the depth of the filter bed.

Because of the care needed in their construction and especially in their operation, open sand filters are recommended only for use in communities which can afford the services of competent sanitary engineers and sewage-plant operators. The advice and approval of the local health department should be sought prior to their construction.

Fig. 54. OPEN SAND FILTER

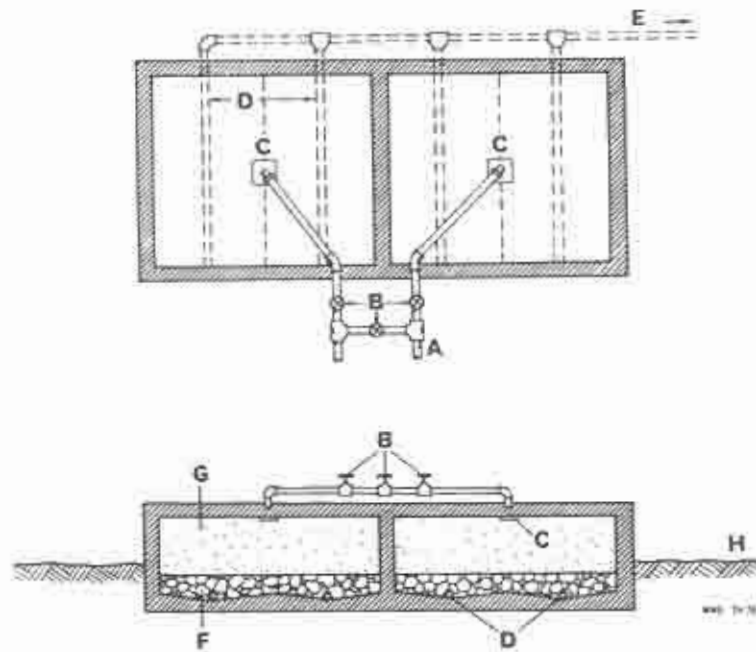

- A = Cast-iron pipe lines from dosing chamber
- B = Control valves, allowing for cleaning and repairs of filter beds without interrupting operation
- C = Concrete splash slabs; top surfaces are left in rough state
- D = Underdrains, laid 1.8 m (6 ft) or more apart, with open joints to receive filtered effluent
- E = Collector to disposal. Pipes laid with tight joints
- F = Coarse gravel or crushed stone
- G = Coarse filter sand, 75-106 cm (30-42 in.) thick
- H = Original ground-level

Operation and Maintenance

A newly-built septic tank should first be filled with water up to outlet level and then should be seeded with several (5 to 8) buckets full of ripe sludge (or decomposing stable manure ripe enough to give off an ammonia odour).

Sanitation Guidelines

Although the recommended designs provide for desludging about every two years or more, the tank should be inspected every 12-18 months in the case of household installations, and every six months in the case of schools and other public institutions. The inspection should determine:

- (a) the distance from bottom of scum to bottom of outlet (scum-clear space) (see Figure 47), and
- (b) the depth of accumulation of sludge over tank bottom.

The scum-clear space should not be less than 7.5 cm, and the total depth of scum and sludge accumulations should not exceed 50 cm.

Sludge may be bailed out by means of a long-handled, dipper-type bucket, or it may be pumped out by a specially equipped cesspool-emptying vehicle.

The scum and sludge removed from septic tanks will normally contain some undigested material which is still offensive and potentially dangerous to health. It should not be used immediately as crop fertilizer, but may be composted along with other organic wastes (kitchen waste, grass clippings, etc). Alternatively, it should be buried in shallow trenches, 60 cm deep.

Local health authorities may require that the effluent from septic tanks or disposal fields be disinfected before discharge. This is particularly true of hospital effluent, which is likely to contain pathogenic organisms. Chlorination with calcium hypochlorite, is commonly used for this purpose and is applied by means of hypochlorinators.

Because of the need for regular and careful maintenance to ensure the proper operation of septic tank systems, it is recommended that members of the community be trained in their maintenance and repair. Local health authorities should stimulate the formation of co-operatives or the setting-up of private concerns willing to undertake the maintenance work. These authorities should be able to provide technical guidance in response to public requests for advice on septic tank construction, operation and maintenance.

Sanitation Guidelines

Suggestions for Construction

Construction of a septic tank system normally requires technical planning and supervision by engineers or experienced building contractors as well as skilled labour. Construction procedures vary a great deal from one country to another. The following suggestions are given only as a guide to the middle level sanitation technician whose duty it will be to ensure:

- (1) that the system is being built according to his overall design, and
- (2) that it operates satisfactorily after completion.

A. General construction steps

1. Assemble all materials, tools, workers, and drawings needed to begin construction. Study all diagrams carefully.
2. Locate the site of the tank using the location map and mark it on the ground with wooden stakes or pointed sticks as shown in Figure 55.
3. Excavate the trench from the building to the septic tank site with a downward slope of between 1 in 50 to 1 in 100. Figure 56 shows the slope of the pipe trenches. Avoid bends. The trench need not be more than 300 mm wide and 300 mm deep.
4. Lay sewer pipe in the trench. Seal all pipe joints with tar, mortar, oakum, or other local caulking materials. Pour water in the pipe at the building to see if it flows through the entire pipe. If it does not, re-excavate the trench and relay the pipe until the slope is correct.
5. Excavate the septic tank. Allow for outward slope of the sides (at least 1 in 10), and for a working area at least 30 cm wide around each side.
6. The bottom of the pit should be level.
7. Spread 75 mm of sand, gravel, or crushed rock on the bottom of the excavation.

Fig. 55. SEPTIC TANK SYSTEM - STAKING SITE

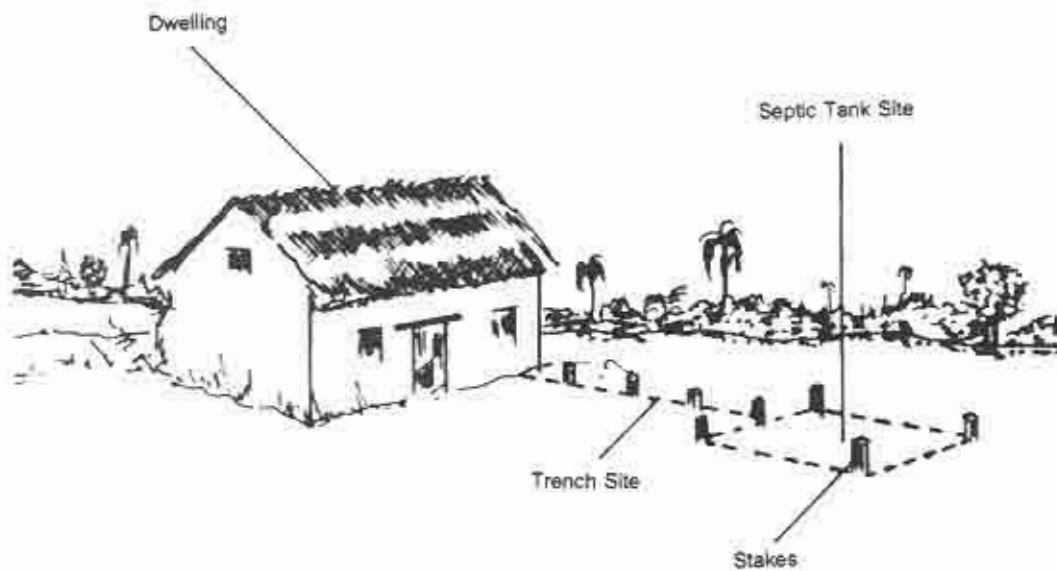

B. For Reinforced Concrete Tank

1. Follow "General Construction Steps" 1 to 7 above.
2. Build wooden forms for the tank floor according to the design dimensions (length, width and thickness). The floor should not be less than 10 cm thick, with adequate reinforcement. Align forms with the sewer pipe. Check the distance down from the end of the sewer pipe to the top of the forms. This distance must be 75 mm plus the liquid depth.
3. Mix concrete with the proper proportions of cement, sand, gravel and water. A common mix by volume is one part cement to two parts sand to three parts gravel and enough water to make a fairly stiff but workable mix.

Fig. 56. SEPTIC TANK SYSTEM - EFFLUENT DISPERSION TRENCH AND PIPES

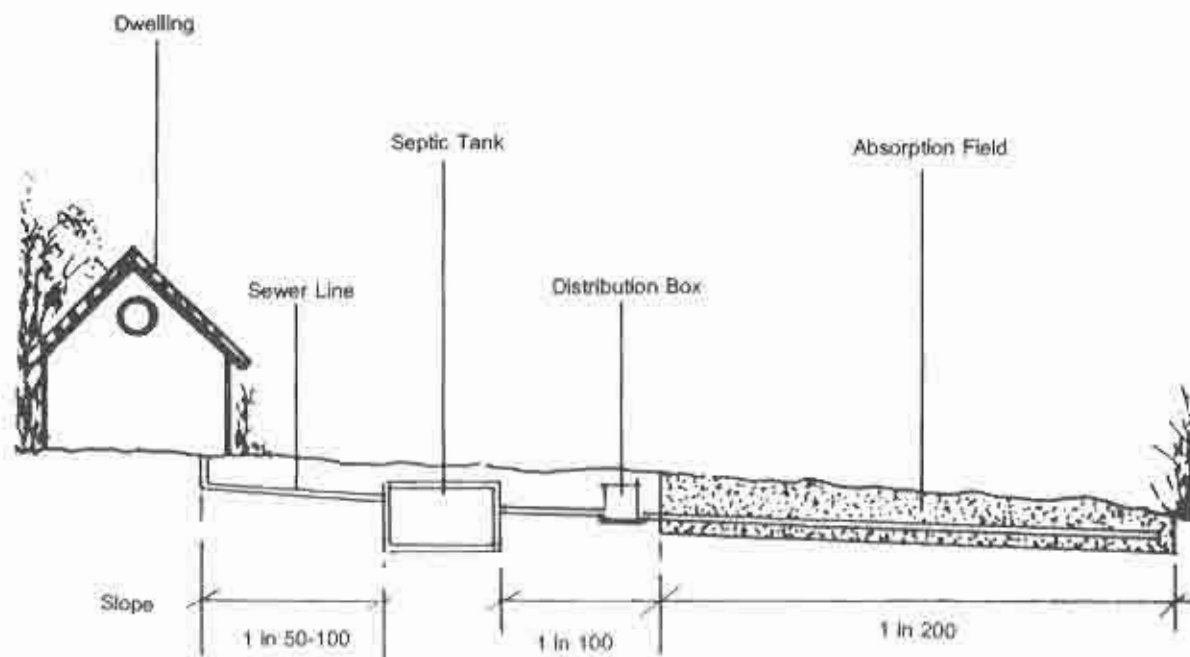

Sanitation Guidelines

4. Pour concrete into forms. Use a stout stick or steel rod to work concrete into the forms and between the reinforcing material. Leave no voids. Use a board or trowel to smooth concrete surface.
5. Cover freshly trowelled concrete with straw, burlap bags, or other material to prevent concrete from drying out too rapidly and losing strength. Keep this cover material moist for seven days, then remove the cover material and the wooden forms. During this curing period, continue with steps 6 and 7.
6. Build forms for the septic tank top, as shown in Figure 57. The top is made in sections which must be strong enough to withstand the weight of earth cover and occasional extra loads. Each section is 300 mm wide and its length equal to the outside width of the septic tank.
7. Mix and pour concrete into the forms as described in steps 3 and 4.
8. Set handholds into the concrete near both ends of each top section. Follow step 5.
9. Build wooden forms and position reinforcing material for the walls of the tank. Build these forms in place on the concrete floor of the tank. Brace the forms to prevent the risk of collapse when the concrete is poured, as shown in Figure 58. The walls should be not less than 10 cm. thick, with adequate reinforcement.
10. Set one pipe section for the inlet and one for the outlet in place in the forms before pouring concrete (this may require some realignment of reinforcing material), then pour concrete for entire wall. It is most important that the inlet and outlet fittings are set at the correct elevations.
11. Mix and pour concrete into the wall forms as described in earlier steps.
12. Trowel tops of walls smooth and cover with moist material as described in step 5 above. Leave cover material and forms in place for seven days, then remove.
13. Use mortar 1:3 (one cement, three sand) for the joints between walls and floor to ensure that the tank will be water-tight. Mortar inlet and outlet pipe "T" fittings in place, and mortar extensions to the fittings.
14. Extend the sewer pipe to the inlet fitting and mortar in place.

Fig. 57. SEPTIC TANK SYSTEM - CONSTRUCTION OF TOP OF THE TANK

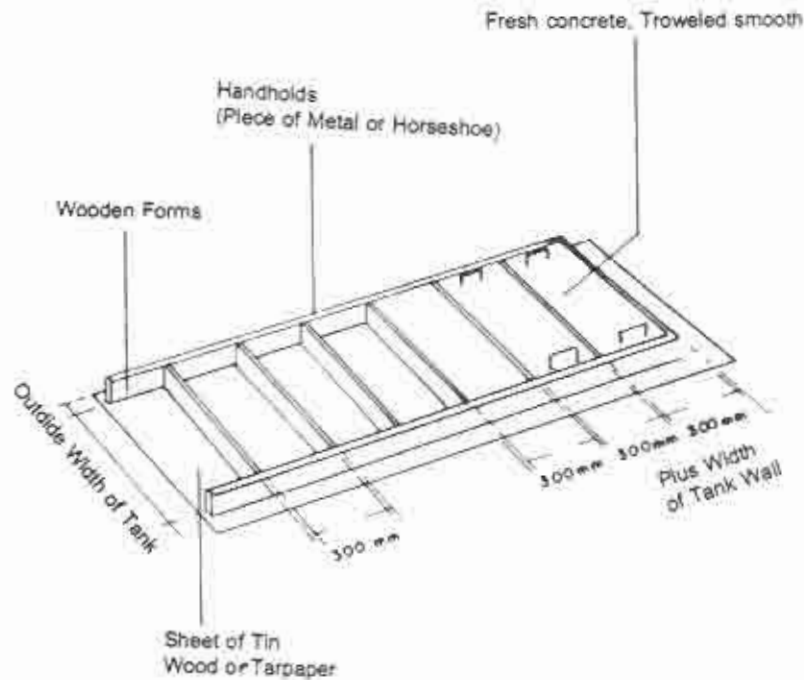

Note: Any number of sections to give outside length of tank.

15. Excavate at least 3 m of trench from the outlet end of the septic tank towards the site of the subsurface absorption system at a slope of about 1 in 100. Extend sewer pipe from the outlet of the septic tank into the trench. Mortar all pipe joints.

Fig. 58. SEPTIC TANK SYSTEM - CONSTRUCTION DETAILS OF THE TANK

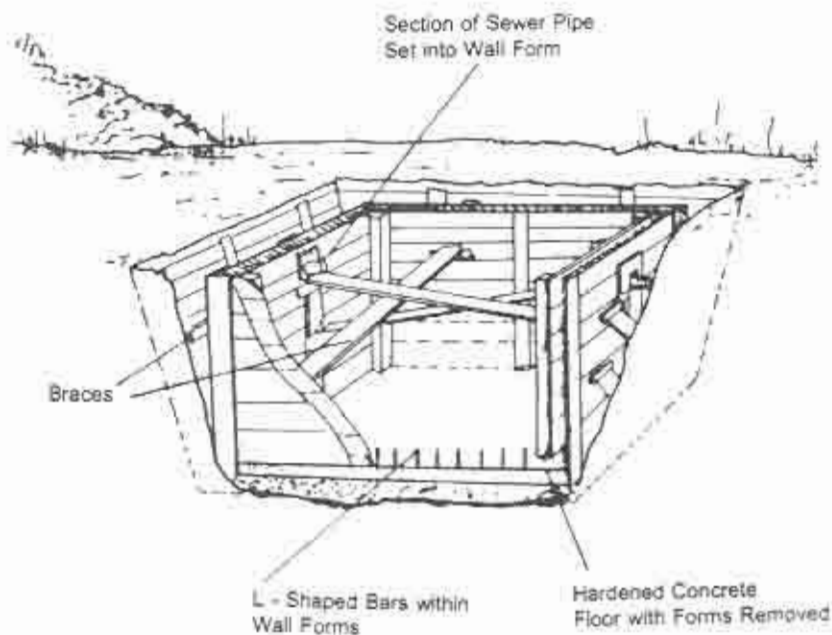

16. Remove cover material and wooden forms from the top sections of the tank. Carefully place sections on top of tank. Thoroughly water proof with tar or other water-proofing material between each section and between the sections and the top of the tank walls.

17. If the top of the tank is below the surface of the ground, cover the tank with a mound of earth to prevent surface water from forming a pool on top of the tank. Mark the tank site with sticks, stakes, piles of rocks, or other means to help find it at inspection time. Preferably, a raised inspection cover above the tank inlet should be provided. For large tanks, two inspection covers (one above the inlet and the other above the outlet) are necessary. The minimum size of manhole should be 50 cm square, or 60 cm in diameter.

Sanitation Guidelines

C. For Brick Masonry Tank

1. Follow "General Construction" Steps 1 to 7.
2. Follow construction steps "For a Reinforced Concrete Tank" 1 to 8.
3. Remove cover material and wooden forms seven days after pouring concrete for the tank floor. Using masonry stone, bricks and cement mortar, begin to build up the walls of the septic tank.
4. When the walls attain the proper height, install the "T" fittings on the inlet and outlet pipes. Be certain that the elevations of these fittings are correct. Mortar the joints around the fittings and extensions to the fittings. These may have to be braced with wood until the mortar sets.
5. Continue building up the walls to the top. If hollow blocks are being used, fill in the hollow spaces in the top layer.
6. Plaster the inside walls of the septic tank with a 25 mm layer of cement mortar 1:3 mix. Apply the layer in two applications of 12 mm each. Let the first layer set for several days before applying the second.
7. Follow the construction steps "For a Reinforced Concrete Tank", 14 to 17 after the walls have set for seven days.

(Note: The septic tank is part of a system and is not ready to operate until it is connected by sewer line to a subsurface absorption system.)

Cost

Septic tanks and their drainage fields are among the most expensive forms of household waste disposal. In some countries, their operation and maintenance costs, on a community basis, have been found to exceed the costs of conventional sewers and sewage treatment by as much as 50 per cent.

Advantages and Disadvantages

The main advantage of septic tank systems is their flexibility and adaptability to

Sanitation Guidelines

a wide variety of individual household waste disposal requirements. Septic tanks are only appropriate for houses that have both an in-house water supply and sufficient land for effluent disposal. These two constraints effectively limit the responsible use of septic tanks to low density housing areas. In such areas they are a very acceptable form of sanitation.

Their major disadvantages include large space requirements, the need for a reasonably high degree of user attention, and high costs.

The main physical factors that affect the suitability of septic tanks are soil permeability, space available for drainage fields (subsurface irrigation), level of water service, and proximity of underground drinking water sources.

3. Other Excreta Disposal Options

3.1. On-Site Technologies

3.1.1. Borehole latrine

Description

The borehole latrine is a variation of the conventional pit latrine. Its pit has a much smaller cross-sectional area which makes it a less desirable type of installation for disposal of excreta. The bored-hole latrine slab and superstructure are the same as for the pit latrine (see Figure 59).

Components and their Design

The Borehole

This consists of a circular hole, usually 40 cm in diameter, bored vertically into the ground by means of an earth auger, or borer, to a depth of 4 - 8 metres, most commonly 6 metres (see Figure 59). Holes of diameters 30 cm and 35 cm have also been used extensively, and are easier to bore but experience shows that their capacities are much too small.

Because of its small capacity, the borehole latrine dug into dry ground and used by a family of 5 or 6 does not usually last more than one and a half to two years - less where bulky cleansing materials are used.

The lifespan can be extended by boring two holes a short distance apart. When the first hole is filled, it is covered with 50 cm of well-tamped earth, and the slab and superstructure are relocated over the second hole. After about one year, the well-digested material in the first hole may be removed, making the hole available for the

Sanitation Guidelines

next move. The life of a borehole latrine (like that of the pit latrine) is appreciably increased when it penetrates into groundwater although this in turn presents a significant health risk. Because of its small capacity, the bored-hole latrine is appropriate for household use but should not be considered as an option for public use.

The greatest difficulty encountered in the construction of bored-hole latrines is the collapse or caving of the pit walls. Collapse is fairly frequent, especially in sandy or alluvial soils, and is sometimes so severe as to obstruct the hole completely. Holes have been bored into dry and firm ground requiring no casing and have caved in during the next rainy season when the groundwater rose and flooded the hole. To avoid such occurrences, casings or linings may be provided to support the walls of the hole although this will add significantly to the construction cost. When planning borehole latrine installations it is important to study ground formations and fluctuations of groundwater levels in the area under consideration.

Because of the small dimensions of the borehole, the upper section is likely to be soiled by both excreta and urine. This may result in offensive conditions, and flies may be attracted and breed in the earth below the squatting plate. To alleviate this situation, it is good practice to line the upper 30-60 cm of the borehole with a tight, impervious lining (e.g. concrete, baked clay).

The Slab

The floor of a borehole latrine is identical in size and shape to that of the pit latrine. When the floor is built of concrete, it needs little or no reinforcement because of the small unsupported span (40 cm) of the borehole latrine slab. The thickness of the concrete slab may be safely reduced to 5 cm on the slab edge and to 4 cm at the centre. Hog-wire or similar reinforcement should be used to prevent cracks caused by temperature differences or shocks during transportation. The floor is usually raised 15-20 cm above normal ground level, but a specially built base is generally not necessary.

The Mound

A mound of earth should be built around the floor to protect it against run-off. The mound should be at least 50 cm wide and well tamped. In flood plains and tidal areas, the floor should be elevated above the highest water level, and the mound solidly built. As shown in Figure 59, the mound may be built of moist earth in well-

Sanitation Guidelines

tamped layers of 15 cm depth. Where necessary, the mound should be revetted with flat stones.

As in the case of the pit latrine, it is preferable to supplement the earth mound in front of the entrance door with a masonry or brick step. This will help prevent dirt from being trodden inside the latrine from the user's feet.

The Superstructure and Ventilation

The superstructure is identical to that recommended for pit latrines. It should be ventilated to minimise odour. Ventilation of boreholes is generally considered to be unnecessary.

Location of Borehole Latrines

The basic considerations regarding the placement of latrines in general with respect to sources of water supply and dwellings have already been discussed. In the case of the borehole latrine, there is a risk of groundwater pollution if it is constructed so as to deeply penetrate groundwater in order to achieve more efficient and durable operation. This should not be undertaken close to (i.e., within 30 metres) of sites of groundwater abstraction for drinking. The general rules governing the location of borehole latrines are the same as those for the pit latrine.

Advantages and Disadvantages

The main advantages of the borehole latrine are:

- (i) cheapness;
- (ii) ease of construction.

The disadvantages of the borehole latrine are many:

- (i) small capacity and short life;
- (ii) possibility of caving;

Sanitation Guidelines

- (iii) no ventilation;
- (iv) possible odour and fly nuisance, and
- (v) special equipment required for its construction.

Fig. 59. TYPICAL BOREHOLE LATRINE

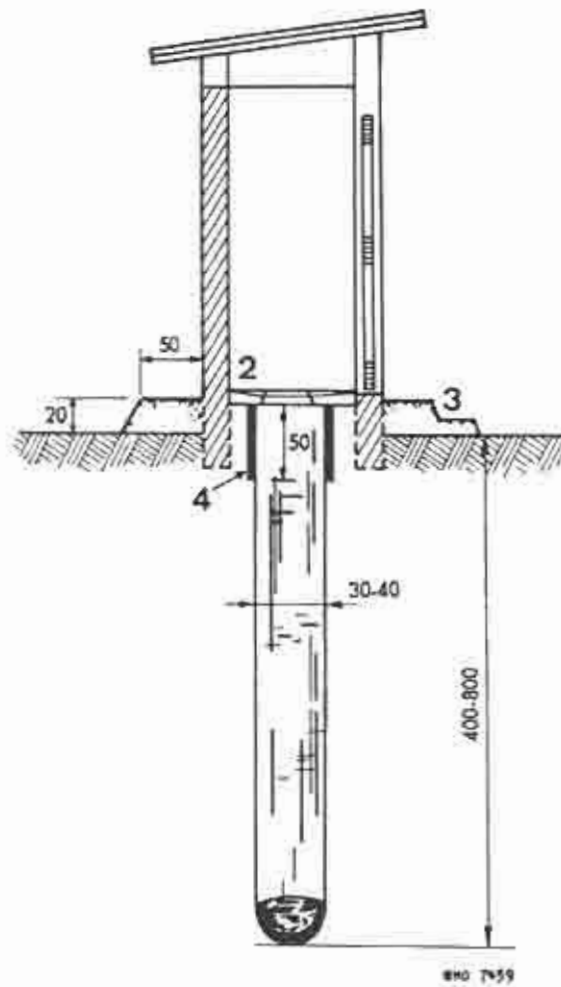

Measurements shown are in centimetres

Sanitation Guidelines

Penetration of groundwater is both an advantage and a disadvantage, as previously noted. It is an advantage because it will generally increase the lifespan of the latrine. It is a disadvantage because it tends to induce collapse of borehole walls and because of the risk to health caused by groundwater contamination. In addition, the formation of a thick scum above the water level in the hole may seriously impair the operation and life span of the latrine. In such situations the borehole fills up quickly since the solids deposited float over the scum. This is especially true in areas like the Nile Delta in Egypt where heavy groundwater fluctuations may bring the water table to within a few feet of ground level. By breaking the scum layer with a pole (a procedure which is admittedly impractical in many instances), the efficiency of the latrine may be restored.

In summary, the borehole latrine is classified among the less desirable excreta disposal technologies and is seldom recommended for widescale use. However, as a temporary measure, or for emergency use, the borehole latrine can be a valuable installation.

3.1.2. Overhung Latrine

The overhung latrine consists of a superstructure and a latrine floor built on top of wooden poles above water. It is found around seaports and fishing villages in every continent and is very common in coastal areas of some Asian countries where many people inhabit land areas that are frequently or periodically covered with water. For people living in raised huts with cat-walks for streets, water supply and sanitation are problematical. In the case of brackish rivers or tidal flats, drinking-water is difficult to obtain and inhabitants may rely on rain water or well water from a distant source.

Under such circumstances a carefully located overhung or "drop" latrine may be the only available excreta disposal technology. Nevertheless it should be recognised that it represents an enormous health hazard and should only be employed where no other options are feasible. The health hazard which such a latrine represents may be reduced if the following general conditions are met:

- (1) The receiving water is of sufficient year-round salinity to prevent human consumption;
- (2) The latrine is installed over such water depth that the bed is never exposed during low tide or the dry season;

Sanitation Guidelines

- (3) Every effort is made to select a site that will carry floating solids away from habitation and facilitate dilution;
- (4) There is a minimum stream flow of 14 litres per second per family for adequate dilution;
- (5) The walkway, piers, squatting openings, and superstructure are made structurally safe for adults and children.

However, in general, this is an unacceptable excreta disposal technology, and should not be considered as a possible option for the following reasons:

- (a) The very high degree of faecal contamination which will inevitably arise and present a significant health risk;
- (b) The universal habit of prolonged contact with water in bathing and fishing; and
- (c) The possibility that this type of latrine would become established upstream, where it would empty into smaller and fresh-water courses.

3.2. Off-site Technologies

3.2.1. Bucket Latrine.

The bucket latrine consists of a bucket in which excreta are deposited and which is removed for emptying and cleaning at frequent intervals.

The Bucket or Receptacle

The bucket or receptacle is usually made of seamless galvanized iron, rubber, or white enamel. Typically, it is about 38 cm in diameter at the top and 30 cm deep and has a handle for lifting and carrying. Ideally it should be provided with a removable, tight-fitting lid held in place by clamps. It is better practice to have two buckets, painted different colours, available for each latrine hole or seat so that a clean pail may be placed in the latrine when the other pail is taken away for emptying.

Sanitation Guidelines

The Collection Chamber and Superstructure

The bucket is placed in a collection chamber (or box) situated below the squatting plate (or seat), as shown in Figure 60. The chamber may be built of brick or concrete, with rounded corners so as to help centre the pail. Most chambers open to the rear of the latrine into the service lane used for collection. Where seats are used, the space beneath constitutes the box, and the pails may be removed through the hinged latrine seats.

It is important that the collection chamber be fly- and animal-proof. The chamber should also be ventilated by means of a pipe vent carried to roof level of the superstructure. The vertical distance between the bottom surface of the floor slab and the rim of the bucket should not be greater than 2.5 cm.

The superstructure itself is built in the same manner as for an ordinary pit latrine, except that the floor is raised above the collecting chamber and ground level. In some countries the floor is designed in such a manner as to separate solid faeces. Urine and ablution water tend to fill up the buckets quickly and keep their contents in a semi-liquid state. Urine and other liquid wastes are therefore directed by troughs to either an impervious catchpit, which is emptied periodically, or to a soakage trench.

Collection and Conveyance of Buckets

Collections are usually made daily, although in some places they are made only weekly or even less frequently. The collected pail should be sealed with a fly-tight lid and replaced by a clean and disinfected one of different colour, eg. all buckets collected on a Monday are red and all replacement buckets on that day are yellow so as to help distinguish the buckets which have been disinfected from those which have not. Sometimes the contents are emptied into a tank carried by a vehicle, and the bucket taken away to be washed. The practice of emptying buckets into a tank or wagon and immediately returning them to the latrines is unreservedly condemned.

Methods of transportation vary widely and include the "basket" system, push-carts, bull-carts and motor vehicles. Spilling the contents of the buckets must be avoided during collection and transportation to the disposal grounds.

Fig. 60. THE BUCKET LATRINE

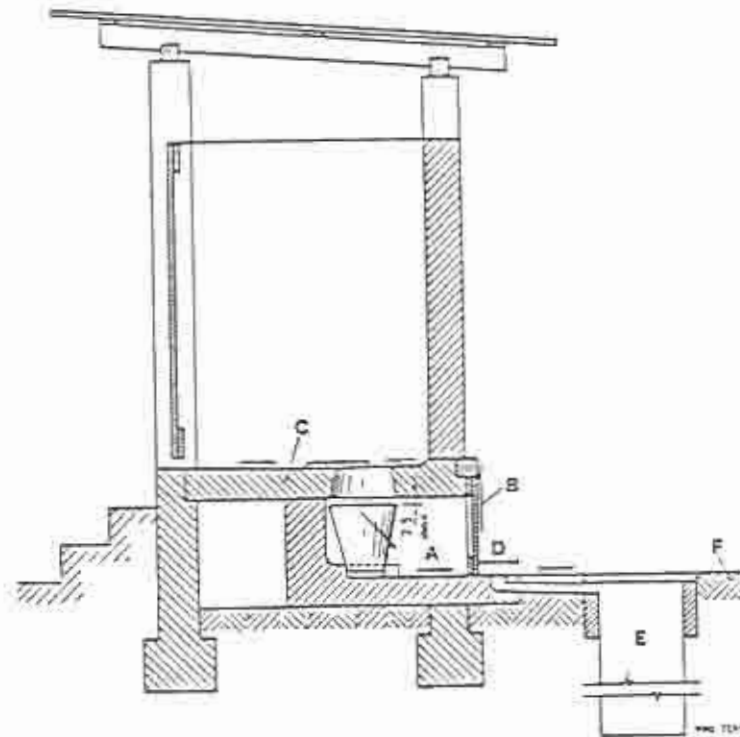

The measurement shown is in centimetres

- A = Collection chamber built of impervious material; note bucket
- B = Fly-proof door
- C = Elevated floor or slab
- D = Paved surface and drain
- E = Soakage pit or trench
- F = Original ground level

At the disposal site the buckets are emptied, thoroughly washed, and disinfected with a phenol or creosol type of disinfectant before being stored away and re-used. The wash water is disposed of underground by means of soakage pits, and should not be permitted to run freely in open ditches or used, without adequate control by local

Sanitation Guidelines

health authorities, for farm irrigation. Disposal sites should be isolated from human habitations and remote from sources of drinking water.

The collection system is best carried out by the community administration and under direct supervision of the health authorities. A fee is usually paid by the family for this service, sufficient to cover operation costs and replacement of equipment.

Methods for Final Disposal of Night-Soil

Night-soil is the term used to describe human excreta transported without flushing water.

- a) Disposal of nightsoil into water bodies is practised in some areas but generally presents a very high health hazard. This is especially the case with surface waters which may be used downstream for drinking or other domestic purposes.
- b) A simple and common, but labour intensive, method is to bury the night-soil in earth pits or trenches.
- c) Incineration of night-soil along with other types of refuse fulfils sanitary requirements but is expensive.
- d) Retention in specially designed tanks is practised in some Asian countries where human excreta is used as a fertilizer. Co-composting with other organic materials - often wastes - may also be practiced. Public health criteria are fulfilled if the retention period is of sufficient length to ensure that pathogens are destroyed. The cost of this operation depends on the cost of storage and transport and the selling price of the fertilizer produced.
- e) In some countries, raw or partially decomposed night-soil is used for agricultural purposes. This practice is universally condemned on public health grounds.

Advantages and Disadvantages

The only advantage of the bucket-latrine system is that it offers a means for collecting night-soil which, in some areas, is ultimately used as soil fertilizer. It has many disadvantages. The act of emptying the bucket typically involves spillage and the area becomes heavily contaminated. A bucket latrine system, though cheap in

Sanitation Guidelines

initial cost, is in fact very expensive to operate and maintain. In addition, it has obvious health hazards for the community and the collectors, in particular. A bucket-latrine system may lead to social problems because of the stigma attached to the collectors. Where this method is used it is becoming increasingly difficult to recruit labour for collecting. However, in rural areas it may still be possible to secure the co-operation of interested farmers for this job.

A bucket-latrine system can only work well under situations of tight institutional control, where all operations are carefully supervised. It should generally be regarded as a temporary measure suitable for camps, for instance, while more permanent solutions are constructed.

The use of dry earth, sawdust, or ash is often ignored even in areas where the latrine is still called a "dry earth closet" or *tinette*. As a result, the contents of the buckets are highly odorous and attractive to flies, which lay their eggs in them at the first opportunity. The door of the collection chamber and the squatting hole or seat are seldom fly-proof and closed. In spite of active supervision, the contents of buckets are often spilled carelessly near the latrines or along the road to the disposal site. The bucket lids are rarely kept in place and coverless buckets are sometimes left exposed for hours in the street pending collection. The system which depends on the separation of urine and faeces is seldom built and maintained properly. As a result the urine runs over soaked ground and forms unsightly pools. Conditions at the disposal sites are often intolerable due to spillage, inadequate water supply, intense fly-breeding, odours, and rodent infestation. Owing to the enormous difficulties in operating this system in a sanitary manner, the bucket latrine usually violates most, or all, of the sanitary requirements.

The cost of operation of this system is, in most instances, very high, although this is not often recognized by town councils. It is strongly recommended that communities which use the bucket-latrine system undertake a thorough sanitary and financial study of their operation with a view to changing to a safer and more economical excreta disposal technology.

3.2.2. Vault and Cartage Systems

Description

Vault latrines are similar to the Pour-Flush (PF) toilets, except that excreta are discharged into a sealed vault that is emptied at regular intervals (see Figure 61).

Fig. 61. ALTERNATIVE DESIGNS FOR VAULT LATRINES

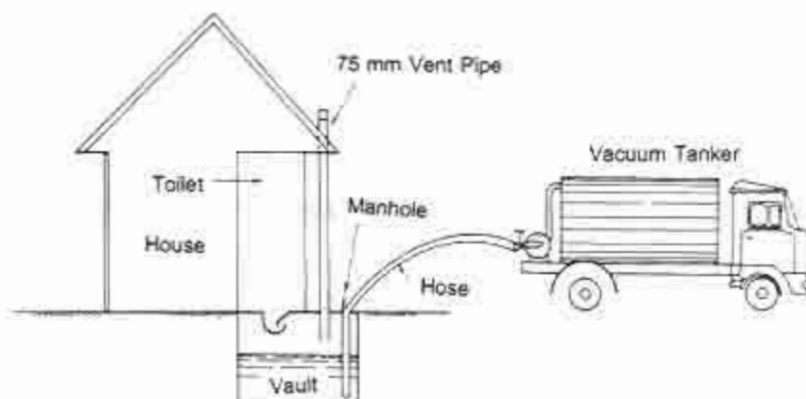

Vault Below Squatting Place

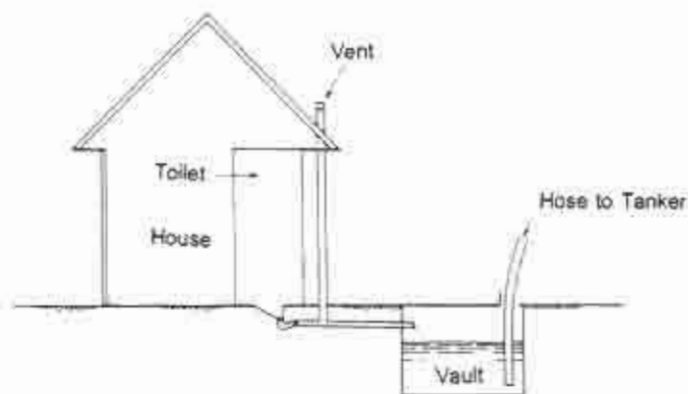

Offset Vault

The vault should be emptied by vacuum tanker (i.e. a tanker-truck equipped with a regular or vacuum pump), although in areas where access is difficult it may be necessary to use alternative methods as described below. The vault latrine may be

Sanitation Guidelines

installed as a pour-flush toilet either with the vault immediately below the squatting plate or with a completely offset vault. In the latter case the vault may be shared with adjacent houses, with some savings in construction costs.

Components and their Design

The vault volume may be calculated from the following equation:

$$V = \frac{N \times Q \times D}{K}$$

where

- V = vault working volume in litres;
- N = average number of users;
- Q = excreta and flushing water, litres per person per day;
- D = the number of days between successive emptying of the vault;
- K = vault volume underutilization factor.

From 0.8 to 1.8 litres per person per day of night-soil are collected from vault latrines. The maximum probable combined excreta and flushing water for vault latrines may be estimated as 10 litres per person per day. The vault volume underutilization factor, K, is introduced since the vault will normally be emptied before it is completely full. In areas where tanker collection is excellent, K may be taken to be 0.85; in other areas K may need to be as low as 0.5.

The vault working volume, V, and the number of days between emptying, D, are directly proportional to each other. Once vault construction and emptying costs are known, it is therefore possible to minimize the total cost by optimizing the combination of vault size and emptying frequency. The vault need not be very large; for example, for a family of six producing 10 litres per person per day, if the vault is emptied every two weeks and K is taken as 0.5, the required vault volume is only 1.68 cubic metres. Each time the vault is emptied 0.84 cubic metres of night-soil must be removed.

The vault may be constructed from concrete, brick, or concrete blockwork suitably rendered with a stiff mortar to make it watertight. Small vaults may be constructed from prefabricated plastic tanks if they are locally available and economi-

Sanitation Guidelines

cally competitive. Loss of water from a vault latrine may cause pumping problems; vault contents with more than 12 per cent solids may have to be scooped or ladled.

Collection Vehicles

In order to minimize collection costs, night-soil collection vehicles should, in general, be as large as possible. Vacuum tankers usually have capacities of 1,500 litres. The length of vacuum tubing that can be attached to them can be as much as 100 metres. In areas where access is difficult even this length is insufficient and smaller collection vehicles must be used. These may be hand- or animal-drawn carts with capacities of only a few hundred litres equipped with manually operated diaphragm pumps, or small mechanically or electrically operated vehicles (even three-wheeled vehicles) fitted with mechanically operated pumps.

Since vault latrines are considerably cheaper than sewerage, it is extremely important that design engineers consider all possible collection methods, even though this may usually mean that some site-specific improvisation is required. Access may be extremely difficult, but only very rarely will it be impossible for some sort of vehicle to be used to empty the vaults. For those households where it is not possible, manual emptying of the vault by the dipper and bucket method may have to be used. This is only a marginal improvement in collection practice over bucket latrines as some night-soil spillage is inevitable. A pipe connection to an accessible communal vault is recommended in such cases.

The average number of vaults that a tanker can empty each day depends on the ratio of tanker size to vault size, the average distance of the tanker depot and disposal point or treatment works from the vaults to be serviced, the average time taken to empty one vault, the average distance between vaults, and the speed of the tanker.

Disposal of Vault Contents

The tankers transport the vault contents to a trenching field, a night-soil treatment works, or a marine discharge point. In the trenching method of disposal, the excreta is deposited and spread on the bottom of long, shallow (50 to 60 cm deep) trenches. The trenches are then filled with a layer (not less than 30 cm thick) of well-tamped earth. It is in this top layer of the soil where aerobic saprophytic bacteria are most numerous and active. These bacteria reduce the offensive material in a short time in warm climates (usually a few months). The trenching field should be located

Sanitation Guidelines

far from the community and in such a way that odours will not be carried back to the community by prevailing winds. The trenching operations must be carried out under strict sanitary supervision.

In areas where excreta is re-used as soil fertilizer, vault contents are taken to special night-soil treatment works where they undergo decomposition, or are composted, under controlled conditions and temperature. The humus produced is hygienically safe and valuable as fertilizer.

In other areas, vault contents are simply dumped into the sea at a distant point from the community in a usually unsuccessful attempt to avoid possible pollution of nearby recreation shores.

If small tankers or other collection vehicles are used, it may be necessary to provide transfer stations. Night-soil is transferred to larger vehicles for conveyance to the treatment works or discharge point in order to minimize vehicle haulage distances and hence collection costs.

Adequate tanker washwater should be available at the treatment site or marine disposal point.

Advantages and Disadvantages

The vault and cartage system fulfils environmental health criteria if, at every stage of excreta collection, cartage and disposal, strict sanitary precautions are taken to avoid possible spillage and pollution of the environment. The system may be suitable for communities (especially in urban areas) where housing density is high, and for medium-rise buildings. Excreta can readily be flushed down a vertical pipe (e.g. in Yemen) into a covered vault at or below ground level.

The principal advantages of vault latrines are as follows:

- (1) low initial cost for the householder;
- (2) high labour requirements, with consequent generation of employment (provided, of course, that local people have no taboos against working with excreta);
- (3) minimum water requirements;

Sanitation Guidelines

- (4) possible location within the dwelling;
- (5) high potential for resource recovery;
- (6) reduced risk of groundwater contamination.

The main disadvantages include the following:

- (1) high cost of tankers and of transfer and disposal installations which may be required;
- (2) in most developing countries, foreign exchange is required to pay for the collection tankers and pumps;
- (3) high degree of municipal involvement to ensure equitable and sanitary service, in addition to proper vehicle maintenance.

These disadvantages are serious enough to only justify the vault and cartage system of excreta disposal for special situations where municipal services, including sanitary control, are dependable and efficient.

3.2.3. Communal Sanitation Facilities

Advantages and Disadvantages

Communal sanitation facilities provide a service level ranging from sanitation only to a combined latrine/bathing/laundry unit. Figure 62 shows an example of a communal facility. Their principal advantage is their low per capita cost.

The decision to install communal facilities should never be taken lightly. The most fundamental problem with a communal facility is that it appears to belong to no one so that there is very little commitment by individual users to keep it clean and operating properly. Once a latrine compartment is fouled, the next user may have no choice but to foul it further. As a result many communal latrine blocks are very unhygienic. To avoid this it is advisable to provide one or more well-paid and well-supervised attendants to keep the facilities in good operational order. One way of raising the salaries of the attendants is to introduce a tariff for use of the facilities. Lighting and a water supply must also be provided. It is also essential that the

Sanitation Guidelines

Fig. 62. A COMMUNAL SANITATION FACILITY

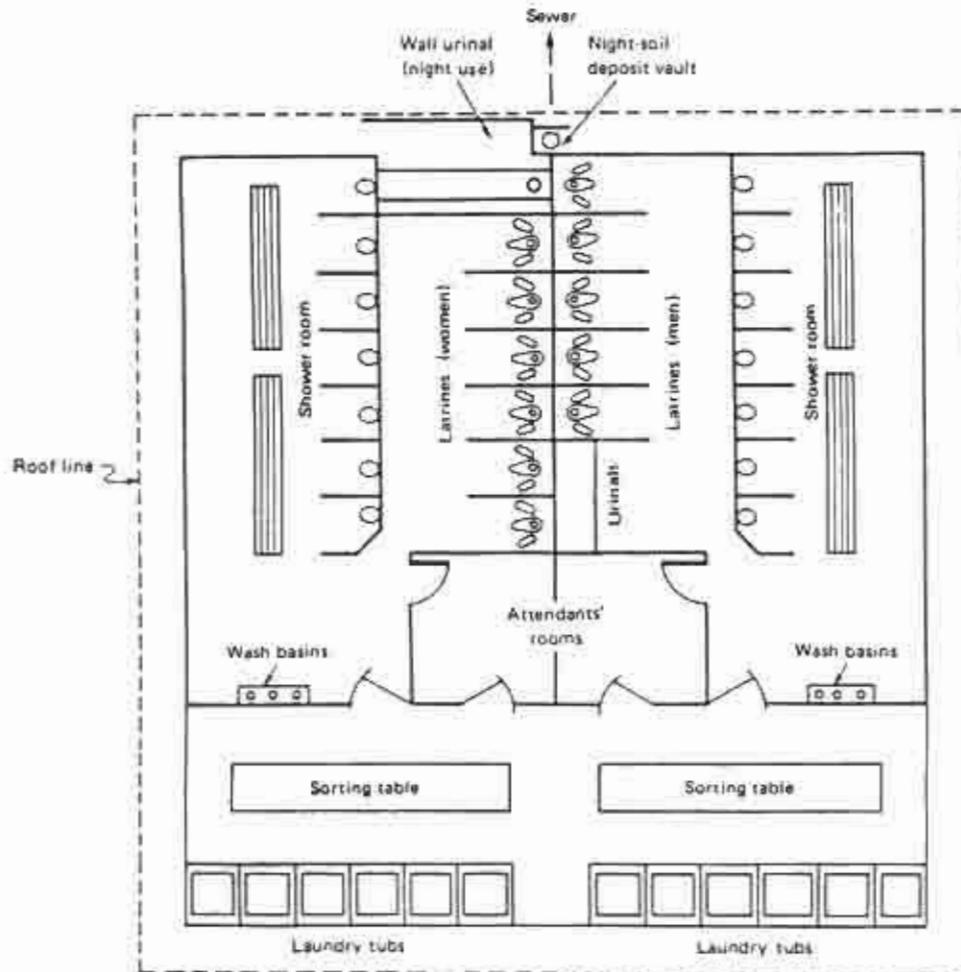

employers of the attendants (often the municipality) should regularly inspect the facilities to make sure that they are being properly maintained.

Technical Appropriateness

There are some technical disadvantages of communal sanitation facilities.

Sanitation Guidelines

First, there is the difficult question of privacy. An individual's requirements for privacy must be clearly understood and respected. Cultural attitudes toward defecation vary, but generally it is regarded as a private personal act. Therefore each toilet within the communal block should be designed as a separate compartment and provided with a door that can be bolted.

This may seem obvious, but there are many public toilet blocks that merely contain a row of holes with no internal partitioning whatsoever. In some societies privacy is not so important. Questions of privacy must be discussed with the community when considering communal facilities. In addition, there is the problem of defecation at night, during illness, and during wet or cold weather. If the communal block is not lit, it may not be used at night. In any case it is unreasonable to expect even fit adults - let alone the young, the old, or the infirm - to walk 100 metres or more in the middle of the night or in torrential rain, often along a dark or muddy street or alleyway, in order to relieve themselves. There must be some general provision for the disposal of nocturnal and "bad weather" excreta.

Communal facilities cannot be upgraded. This means that they should be designed with eventual replacement by individual household facilities in mind. It is sensible to tie the provision of sanitation facilities to a residential upgrading programme; this is particularly advisable in the case of slum improvement schemes.

Communal Facilities Design

There are two basic approaches to the design of communal sanitation blocks. The first is to have a completely public system in which a user can enter any compartment not in use at the time. The second approach is to provide cubicles for the exclusive use of one household. This system is essentially a compromise between public and private facilities. Experience has shown that each household will zealously guard its own cubicle and keep it clean but that maintenance of the communal parts (e.g., the passageways and particularly the effluent disposal system) can cause organizational problems. This second approach is generally preferable to the truly public system, but it is also more expensive since a greater number (depending on the average household size) of latrine compartments is needed. The advantage to the municipality is that it is relatively easy to levy rental fees and collect payment from each household using the facility.

A third approach to the design of communal facilities is to provide a sanitation block of the first type but reserved for the exclusive use of a large kinship group.

Sanitation Guidelines

Individual households that belong to a kinship group (clan or tribe) or "extended family," of between 100 and 1,000 members, are located on the same piece of land, which is held in communal ownership by the kinship group. Each kinship group is (or is planned to be) provided with a communal sanitation block with toilets, showers, and laundry facilities. Part of the construction cost is borne by the extended family and part by the government. The family is responsible for maintenance and for water and electricity charges. This approach to the provision of communal sanitation facilities can only work under suitable social conditions.

Number of Toilet Compartments Required

In the completely public communal sanitation block, the best available evidence suggests that one toilet compartment can serve from between twenty-five to fifty people (although it seems prudent to take a design figure of twenty-five users per compartment).

The toilet compartments should be arranged in separate blocks for men and women. Urinals should be provided in the men's block and the total number of urinals and compartments in the men's block should be the same as the number of compartments in the woman's.

Location

In high density areas (over 1,000 people per hectare), the number of people that can be served by one communal sanitation block (usually 200 to 500 people) will normally determine the required number and location of communal facilities. The maximum distance that people may be expected to walk to the toilet is around 100 metres.

Toilet Type

One of the flushing types of toilet is preferable for communal sanitation facilities. Water use may amount to 15-20 litres per person per day.

Sanitation Guidelines

Shower and Laundry Facilities

If shower and clothes washing facilities are not available in individual households, these can be provided at the communal sanitation blocks (approximately one for every fifty users in warm climates). The water requirement for showering is between 15 and 25 litres per person per day. In addition, handbasins should be provided at the rate of one for every ten users. Their water use may be estimated as between 5 to 15 litres per person per day. Water consumption in both showers and handbasins may be considerably reduced by the provision of water-saving plumbing devices. In cold climates it is usually necessary to provide hot water since the cold water storage tank will not normally contain water warm enough for personal washing.

It may also be necessary to provide laundry facilities. The exact style of these facilities should conform to local preference. Approximately one washing tub should be provided for fifty people. Clothes drying lines may be required.

In communal facilities with compartments reserved for the exclusive use of one household, if space permits then each compartment may contain a shower and handbasin in addition to the toilet. The decision as to whether it is necessary to provide a private laundry tub rather than communal laundry facilities is best taken after discussion with the community.

Effluent Disposal

Generally a low-cost sewerage system should be used but soakage pits for pour-flush toilets and sullage water disposal to storm drains have also been used successfully. If the toilets are of the flushing type, a septic tank should be provided so that the sewers can be of small diameter and laid at flat gradients. If the toilets are aqua-privies, a settlement tank will be included in the design and provision needs only to be made for a small tank to settle sullage. If the terrain is such that velocities of 1 metre per second can be obtained in the sewer without the need for excessive excavation or pumping, the sewerage system can be of the conventional kind and the septic tank would no longer be necessary. Where communal sanitation blocks can be installed near a trunk sewer serving other parts of the town, they should be connected to it.

4.0. Low-cost Unconventional Sewerage

The transport and collection of excreta and sullage through buried pipes is generally thought of as an inappropriate sanitation option for small communities in the developing world. This is chiefly because sewerage systems have traditionally tended to be very costly both in economic terms and in the amount of water required for toilet flushing. In addition, such systems tend to be under-utilised in developing countries, where there is a very low rate of connection to the sewerage system.

However, there are now examples in the developing world of sewerage systems which are appropriate for small communities. They operate with the low-volume, pour- or cistern-flush toilet, which use between 3 to 5 litres per flush as compared to between 15 and 20 litres used in conventional sewerage.

Some systems include a sewered interceptor tank, as shown in Figure 63. These tanks are designed to collect solids before they enter the sewer network by preventing the majority of solids from entering the sewer network. The cost of the network may be reduced by using small-bore pipes and flatter slopes. Sewers have been used which have a minimum diameter of 40 mm, compared with 150 mm pipes that are used in a conventional system. In addition, treatment costs will be reduced because screening, grit removal and primary sedimentation will not be required since they will occur in the interceptor tank. In a waste stabilization pond treatment system, anaerobic ponds may be unnecessary.

Latrine pits and septic tanks may be adapted to serve as interceptor tanks which will further reduce costs and small-bore sewerage may therefore provide a means of up-grading in areas where these are common. A disadvantage of the small-bore sewerage system is that the tanks will have to be periodically emptied of sludge which needs to be safely disposed of.

Fig 63. SEWERED INTERCEPTOR TANK

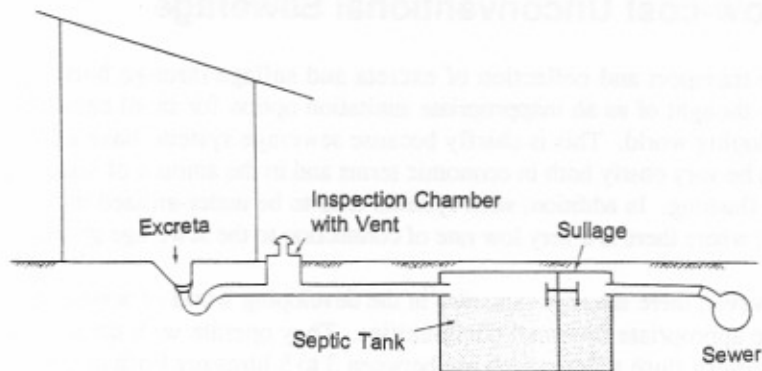

Unconventional sewerage schemes have substantially reduced costs by making the pipe layout as efficient as possible. For example, connecting households to a sewer running through the owners' back-gardens rather than to one under the street at the front of the house. This form of sewer layout has the advantage of reducing the amount of soil cover required by the sewer because the pipe is subject to smaller loads than if it were beneath a road. This type of design is also known as 'shallow sewerage'.

Disadvantages of Water-borne Sewerage

Water-borne sewerage is often considered the ideal form of excreta disposal. Indeed, water-borne sewerage has the advantage that potentially dangerous excreta is rapidly and efficiently carried away from the household. However, it should be remembered that properly constructed and used on-site systems such as V.I.P and

Sanitation Guidelines

composting latrines also treat excreta by containing it for a suitable period and therefore reduce the health risks to the population. Sewerage alone does not do this. While sewerage is effective in removing excreta from the household, unless the sewage is treated, the health hazard is simply transported from one site to another. Discharges of untreated sewage into water courses which are used (albeit downstream) for water supply, irrigation, washing or recreation, present a significant health risk. It is important that the risk to human health which sewerage excreta disposal represents is recognised and that the sewage is adequately treated.

Sewage Treatment

There are various methods available for treatment of sewage; for example trickling filters, activated sludge, oxidation ditches and sewage stabilisation ponds. Some of these treatments are not suitable for reducing the hazard to human health, although the effluent they produce is less toxic to the receiving water course. This is the case with trickling filters for example. Some also require very high levels of operation and maintenance and cannot be recommended for small communities.

A treatment method which is suitable for reducing the health hazard of untreated sewage, which requires less stringent operation and maintenance is by use of oxidation ponds. These will be described briefly here.

Wastewater Stabilisation Lagoons

Description

A typical system for treatment of sewage in stabilisation lagoons for a warm climate would comprise a series of ponds of different depths. The first (primary) pond is often relatively deep. Here, solids settle and intense bacterial activity robs the water of all oxygen and so it is called an 'anaerobic' pond. The effluent from the anaerobic pond flows into a shallower (secondary) pond (e.g. 2 m deep). The secondary ponds are often anaerobic at the bottom but towards the surface where oxygen is absorbed and algae grow (and produce more oxygen) they are aerobic. These ponds are also known as 'facultative' ponds. The effluent from the secondary ponds passes into tertiary ponds (e.g. 1.5 m deep) which are aerobic and which may be used for fish culture.

Fig. 64. LAYOUT OF WASTE STABILISATION PONDS

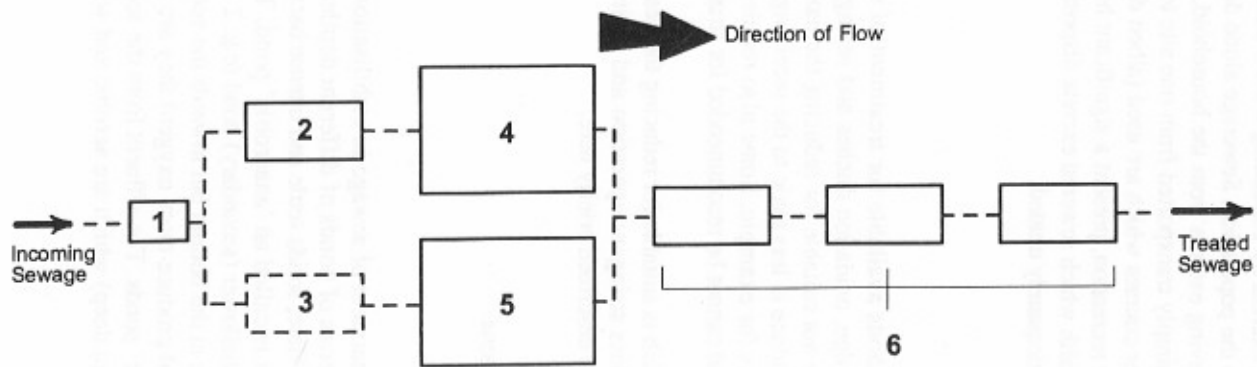

- Key
- 1 = Screens to remove large solids
 - 2 = Anaerobic pond
 - 3 = Spare anaerobic pond
 - 4 = Facultative pond
 - 5 = Spare facultative pond
 - 6 = Series of maturation ponds

Sanitation Guidelines

Normally, two series of ponds are constructed (e.g. a total of six ponds), see figure 64. This is to facilitate cleaning (desludging) when it becomes necessary. The overall retention time of the sewage in the ponds is typically about two to three weeks.

During treatment in stabilisation ponds a number of factors reduce the polluting effect of the sewage considerably. Pathogens both sediment out with particulate material and are killed by the hostile environment. In addition, sedimentation and bacterial activity reduces the load of suspended solids and of substances which would remove oxygen from a river into which it is discharged (biological oxygen demand). The effluent of sewage stabilisation lagoons is nutrient rich and may be used as a combined fertiliser/irrigation water.

Wastewater treatment lagoons require quite large areas of land, ideally downhill of the community and sloping in order that pumping is not necessary. However, they require little operation and maintenance. They are also generally resilient and can accommodate over-loading. With proper operation and maintenance there should be no problems of odour or of fly or mosquito breeding.

Routine maintenance of ponds is largely limited to:

- (i) cleaning and maintaining the inlet and outlet structures;
- (ii) cutting the vegetation from the sides;
- (iii) removing algal mats and scum from facultative and tertiary ponds;
- (iv) maintenance of the 'hard edge' at water level which prevents wave erosion of the embankments;
- (v) cleaning screens and grit channels.

These may be undertaken by unskilled staff under minimum supervision.

Cleaning (desludging) is only required at protracted intervals. Anaerobic ponds may require cleaning every 2 to 3 years, but facultative and aerobic ponds should require cleaning every 20 years or less frequently. The sludge which is removed is often suitable for use as a fertiliser/soil conditioner.

5. BIBLIOGRAPHY

A. Publications Used to Prepare These Guidelines

1. Agency for International Development (U.S.AID) (1982). *Safe Water and Waste Disposal for Rural Health; A Programme Guide*. Technical notes prepared by the (U.S.) National Demonstration Project for A.I.D., as part of the "Water for the World" Series, Washington,D.C.
2. Agency for International Development (U.S.AID) (1982) *Constructing Aqua Privies*. Water for the World, Technical note No. SAN.1.0.4.
3. Cairo University, Faculty of Engineering (1984). *Appropriate Water Supply and Sanitation Technology for Small Egyptian Rural Communities*. Interim Report 2, Cairo, Egypt, March 1984.
4. El-Shamsy, H.E. (1985). *Status of Drinking Water Supply and Sanitation in the WHO Eastern Mediterranean Region*. WHO/EMRO, Alexandria, Egypt.
5. Golladay, F.L. (1983). *Appropriate Technology for Water Supply and Sanitation: Meeting the Needs of the Poor for Water Supply and Waste Disposal*. Volume 13, World Bank, Washington, D.C., August 1983.
6. International Reference Center for Community Water Supply and Sanitation, IRC (1982). *Practical solutions in Drinking-Water Supply and Wastes Disposal for Developing Countries*. Technical paper series no. 20 Rijswijk, the Netherlands, September 1982.
7. Kalbermatten, J.M. *et al* (1980). *Appropriate Technology for Water Supply and Sanitation - A Planner's Guide*, Volume 2, The World Bank, Washington, D.C.
8. Mara, D.D. (1984). *The design of ventilated improved pit latrines*. UNDP/World Bank, TAG Technical Note No.13, Washington, D.C.

Sanitation Guidelines

9. Perrett, H. (1983). *Social Feasibility Analysis of Low-Cost Sanitation Projects*. UNDP/World Bank, Technical Advisory Group (TAG), Technical Note No. 1, Washington, D.C.
10. Pisharoti, K.A. (1975). *Guide to the Integration of Health Education in Environmental Health Programmes*. World Health Organization, Geneva, Offst publication No. 20.
11. Rajagopalan, S. & Shiffman, M.A. (1974). *Guide to Simple Sanitary Measures for the Control of Enteric Diseases*. World Health Organization, Misc. publication, Geneva.
12. Roy, A.K. et al (1984). *Manual on the Design, Construction and Maintenance of Low-Cost Pour-Flush Waterseal Latrines in India* UNDP/World Bank, TAG Technical Note No.10, Washington, D.C.
13. Simpson-Hebert, M (1983). *Methods for Gathering Sociocultural Data for Water Supply and Sanitation Projects*. UNDP/World Bank, TAG Technical note No. 1, Washington, D.C.
14. U.N.D.P (1981) Interregional Project INT/81/047. *Development and Implementation of Low Cost Sanitation Investment Project*.
15. Wagner, E.G.& Lanoix, J.N. (1958). *Excreta Disposal for Rural Areas and Small Communities*. World Health Organization, Geneva, Monograph Series No. 39.
16. Werner D. (1985) *Where There is No Doctor. A village health care manual*. Macmillan.

Sanitation Guidelines

B. Other Publications

1. Feachem, R. *et al* (1981). *Appropriate Technology for Water and Sanitation - Health Aspects of Excreta and Sullage Management - A State-of-the-Art Review*. World Bank, Washington D.C.
2. Feachem, R. *et al* (1983). *Sanitation and Disease - Health Aspects of Wastewater Management*. World Bank Studies in Water Supply and Sanitation No. 3. John Wiley and Sons, Chichester.
3. Feachem, R and Cairncross, S. (1978). *Small Excreta Disposal Systems*. Ross Bulletin No. 8. The Ross Institute of Tropical Hygiene, London.
4. Lanoix, J.N. & Roy, M.L. (1976). *Manuel du Technicien Sanitaire*. Misc Publication, World Health Organization, Geneva.
5. Morgan, P. (1990). *Rural Water Supply and Sanitation* Macmillan Education Ltd., London.
6. Pacey, A. (1986) *Sanitation in Developing Countries*. John Wiley and Sons, Chichester.
7. U.S. Public Health Service. *Manual of Septic-Tank Practice*. Washington, D.C.
8. U.S. Public Health Service. *Individual Sewage Disposal Systems*. Washington D.C.
9. Wegelin- Schuringa, M. (1991). *On-Site Sanitation: Building on Local Practice*. IRC Occasional Paper No. 16. IRC, The Hague.
10. Winblad, U. and Kilama, W. (1985). *Sanitation without Water*. Macmillan Education Ltd., London.
11. World Health Organization (1950). *Expert Committee on Environmental Sanitation, First Report*. Wld Hlth Org. Techn. Rep. Ser., 10, Geneva.
12. World Health Organization (1954). *Expert Committee on Environmental Sanitation, Third Report*. Wld Hlth Org. Techn. Rep. Ser., 77, Geneva.

GLOSSARY

Aerobic

Micro-organisms which require air to maintain life.

Anaerobic

Micro-organisms which will not grow in the presence of air.

Ascaris

Large worm that can live in human intestines.

Alluvial soil

Soil containing clay, silt, sand or gravel formed by the disintegration of rock, that has been deposited by running water.

Beneficiary

Person who benefits from something e.g. a latrine.

Biological

To do with living processes.

Composting

A biological process in which various organisms under controlled conditions break down organic matter into humus.

Cesspool/Cesspit

A pit for collection and disposal of sewage.

Condensation

Conversion of a vapour to a liquid e.g. water vapour to water.

Data

Factual information e.g. measurements.

Decomposition

A biological process in which various organisms break down organic matter.

Digest

Soften or break down a material.

Sanitation Guidelines

Discharge

Release of something e.g. water from a pipeline.

Excreta

Mixture of faeces and urine from human beings.

Effluent

Something discharged into the environment

Entomology

Study of insects.

Faeces

Waste matter excreted from the bowel, consisting mainly of cellulose, unabsorbed food, intestinal secretions and micro-organisms.

Fissure

Narrow opening or crack e.g. in rock.

Geology

Study of the composition of the earth especially of rock formations.

Groundwater

Water under the surface of the ground.

Hand Auger

Tool for boring holes in soil by hand.

Hookworm

Worm which enters the human body through the feet and eventually transfers to the intestines.

Humidity

Quantity of water in a material or the atmosphere.

Humus

The end product of decomposition. A major ingredient in topsoil.

Hydrological

To do with the distribution and circulation of water on the earth.

Hygiene

Actions or practices of personal cleanliness that lead to good health.

Impermeable

Water-tight.

Insanitary

Unclean enough to endanger health.

Interfere

To get in the way of or hinder something.

Larva

Young worm-like form that hatch from the eggs of many insects and parasites.

Larvicide

A poison used to kill larvae.

Sanitation Guidelines

Leaching

Loss of liquid from a material by percolation, usually into the ground e.g. toxic liquid from a waste dump into the ground and possibly into groundwater.

Micro-organism

A tiny plant or animal so small that it cannot be seen with the naked eye.

Nitrogenous

Containing high proportion of the chemical element, nitrogen.

Organism

Living thing (animal or plant).

Organic

Derived from living organisms.

Ova/Ovum

Eggs/egg of parasite.

Pathogen

An organism which is capable of causing disease.

Putrefaction

The breaking down of plant or animal matter.

Parasite/parasitic

Worms or other tiny animals that live in or on another animal or person and cause harm.

Pollution

When water, air or soil is made foul or filthy.

Permeable

Allows water to pass through.

Retention time

The period of time which excreta are kept in a tank or container.

Sullage

Waste water from washing clothes, dishes or personal hygiene.

Sociocultural

Dealing with social and cultural aspects.

Sanitation

Excreta disposal and cleanliness in relation to excreta disposal.

Sewerage

Pipe work taking sewage away from the house.

Sewage

Human waste (faeces and urine) mixed with water and possibly sullage.

Soluble

Can dissolve in something.

Sludge

Solid component of sewage left at the bottom of a septic tank.

Sanitation Guidelines

Seepage

Leaking of liquid from a container into the ground.

Stabiliser

Chemical used to stop something from being destroyed e.g PVC by sunlight.

Schistosomiasis

Disease caused by a tiny worm in the blood stream of humans.

Volatile

Something that rapidly becomes a gas or vapour and is lost into the atmosphere.

Vermin

Animals which cause nuisance.

Waste

Discarded residue to be disposed of and considered to be of no value.

Water table

The level where water is found when a hole is dug.