

## **ORIGINAL ARTICLE**

### **Radioactive Dose Measurement Based on SPECT Gamma Camera: Patient's Dose**

Sulieman M. S. Zobly<sup>1</sup>, Abdelbagi O. Osman<sup>2</sup>

1. Department of medical instrumentation, University of Gezira  
University Street, Wad Medani- Sudan sulieman16@yahoo.com

2. Department of nuclear medicine – University of Gezira, University Street, Wad Medani- Sudan

#### **Abstract:**

A dose measurement is one of the main steps in nuclear medicine imaging, which is done before radiotracer injection of patient. There are different types of instruments used for dose measuring; the most common instrument used is a dose calibrator. So as to get accurate value of the measured dose, the dose calibrator has to be well calibrated regularly. In most cases we need to send the dose calibrator to the manufacturer, standardized organization or reference laboratory for recalibration. Recalibrating the dose calibrator in our department or even in Africa is a challenge. Thus we need to send the instrument to the manufacturer, which costs a lot and takes long time. In this work we want to make use of SPECT gamma camera for measuring the patient dose instead of using a dose calibrator to avoid stopping the work during sending the dose calibrator for calibration or when this device is broken down. We compared the doses that were measured in both the gamma camera and in the dose calibrator device. We developed an equation to enable us to measure the amount of patient dose using SPECT gamma camera. The proposed algorithm validated using different patient doses. The proposed dose measurement algorithm gives the same reading that was obtained with dose calibrator.

**Keywords:** Dose Measuring; Dose Calibrator; SPECT Gamma Camera; Patient Dose

#### **Introduction:**

Measuring the activity of the radioisotope in nuclear medicine is an essential step before injecting the patient for imaging. There are different types of radioactive measurements instrumentation in nuclear medicine, depending on the type of radiation that is being measured and the type of information sought. Instrument

used for radiation measurement have special design characteristics to optimize them for specific tasks. All of the radiation instrumentation has a common performance limitation. <sup>(1,3)</sup>

The radioactive material commonly used in nuclear medicine is a <sup>99m</sup>Tc material. So as to deliver a suitable dose to the patient for the specific test to specific organs, the radiopharmaceutical product has to be measured accurately, and determination of the amount of activity carried out with dose calibrator, which meets the required performance specification given by International Atomic Energy Agency (IAEA). There are different other types of radioactive equipment used for measuring the activity of the patient, and the common one is the dose calibrator device. <sup>(3)</sup>

The dose calibrator is an ionization chamber which consists of two parallel electrodes, cathode and anode with voltage difference between them. A high voltage applied between the electrodes to create electric field in the fill gas. Ion pairs are created, the positive charged (electrons) move to the electrode of the positive polarity under the influence of the electric field. These generate an ionization current, which is measured by an electrometer circuit; the result can be displayed digitally or analogue. The electrometer must be very sensitive to measure a very small output current, which is in the region of femtoamperes or picoamperes, depending on the chambers design, radiation dose and applied voltage.

After patient injection with the radiopharmaceutical, the patient is sent to gamma camera according to specific imaging protocol. There are different types of gamma cameras available nowadays, but all of them have the same operation principles that was used for the first scintillation camera developed by Hal Anger in 1958 <sup>(2, 3)</sup>. In general, the camera consists of sodium iodide NaI (TI) crystal, connected to numbers of photomultiplier tubes (PMTs) connected to a light guide. The output of each PMT is connected to preamplifier. Between the patient and the detector is a collimator, usually made of lead that only allows gamma or x-rays approaching from certain direction to reach the crystal. The amplified signals are sent to Analog-to-Digital Converter (ADC) to generate the image. <sup>(3,4)</sup>

There are many types of gamma cameras, i.e. planar, also there is positron emission tomography (PET) and photon emission computed tomography (SPECT). Gamma camera has been used in different applications such as the

patient imaging, determining hydrodynamic properties of gas/solid and liquid/solid fluidized beds and in visualizing and monitoring of multiphase flow phenomena in porous media. <sup>(5)</sup>

In general the camera consists of sodium iodide NaI (TI) crystal, connected to numbers of photomultiplier tubes (PMTs) connected to a light guide. The output of each PMT is connected to preamplifier. Between the patient and the detector is a collimator, usually made of lead that only allows gamma or x-rays approaching from certain direction to reach the crystal. The amplified signals send to Analog to digital converter (ADC) to generate the image, so as to generate an image, this is displayed in the display device <sup>(3, 4, 6, 8)</sup>. Besides the patient imaging, the SPECT gamma camera has been used in different application such as determining hydrodynamic properties of gas/solid and liquid/ solid fluidized beds and in visualizing and monitoring of multiphase flow phenomena in porous media <sup>(5)</sup>. Figure 1 illustrates the main components of the gamma camera.

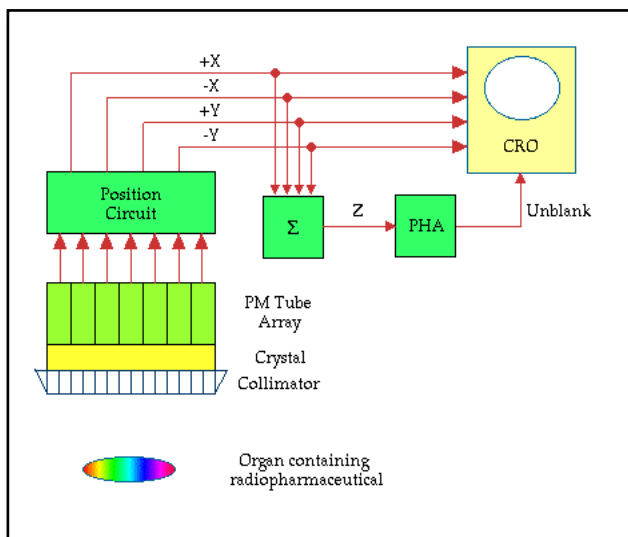
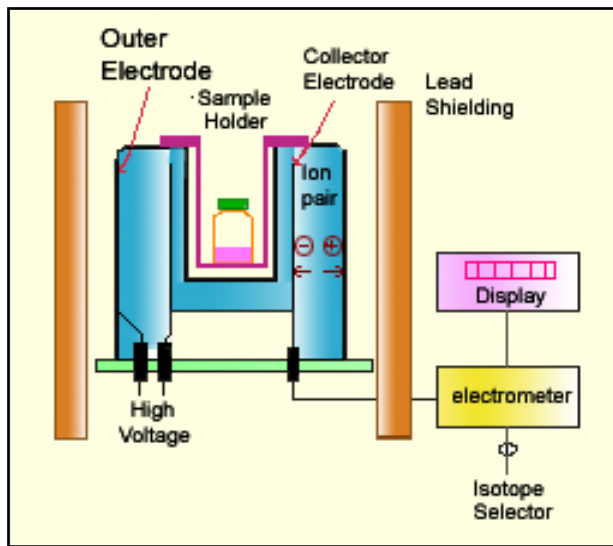

**Figure 1: Main components of the gamma camera**

The dose calibrator is used for measuring the activity of radionuclide's and radiopharmaceuticals before imaging, so as to display the activity in curie (e.g. mCi) or in Becquerel (e.g. MBq). An appropriate quality control is required for dose calibrator to ensure that the correct dose is administrated to the patient <sup>(9)</sup>. A

lower dose may give an inappropriate image, and an increasing dose leads to unnecessary radiation hazard delivered to the patient.

A dose calibrator consists of shielded an ionization chamber, field with a suitable gas, in some cases, it field with air under some pressure, the chamber is in the shape of well, into which the sample to be measured can be placed. Most nuclear medicine counting systems consist of a detector, high voltage supply, preamplifier, amplifier, one or more single-channel analyzer, or a multichannel analyzer, scalar-timer, and rate meter or other data readout device <sup>(3)</sup>. The radioactive source produces ion pairs, positive charges and negative charges. When high voltage is applied to the electrodes, the positive charges move to the outer electrode and the negative charges moved to the collection electrode, causing a very small electrical current flow between the electrodes. The amount of electrical charges is proportional to the activity of the radionuclide. Figure 2 shows the main component of the dose calibrator.



**Figure 2: Main components of dose calibrator**

In this work we want to propose using SPECT for patient dose measurement instead of using dose calibrator so as to solve the problems of delaying the routine work during sending the dose calibrator for recalibration or when the

machine break down. Using SPECT also will help the user to avoid putting a backup machine in the nuclear medicine department, which means saving more money.

The rest of the paper is organized as following: in section II, the experimental systems used to perform the work are discussed, including basics of gamma camera and dose calibrator. Also the experimental setup is discussed in details including the dose acquiring and dose calculation, beside the equation developed for dose calculation measured from gamma camera.

The results of the work and the discussion are found in section III. In section IV, the conclusion of the work is discussed.

## **Material and methods**

### **Gamma camera**

The model available at our department is Mediso *SPRIT*, dual head gamma camera with 55 PMTs in each; low energy high resolution (LEHR) collimator and NaI (TI) crystal with a diameter of 40 cm were used. Figure 3 shows the SPECT gamma camera used to demonstrate this work.



**Figure 3: Mediso SPECT gamma camera**

### **Dose calibrator**

For a patient's injection, accurate and reproducible dose is very important. Thus, the dose measurement is very important in nuclear medicine <sup>(7)</sup>. In most cases, the dose calibrator needs to be recalibrated regularly by sending the instrument to the manufacturer, when the calibration sources (e.g. <sup>57</sup>Co, Cs<sup>137</sup>, Ba<sup>133</sup>, etc.) are not delivered with instrument or there is no calibration sources available. In European countries calibrating the machine is not a problem because of the availability of the companies and their representatives, but in Africa and in some parts of Aisha, sending the instrument to the manufacturer for recalibration is a big challenge, because, sending and returning it back, takes time and costs alot, such as transportation cost, calibration and costumes cost, in some cases, instead of doing the recalibration, it's better to buy a new one.

### **Experimental setup**

The test performed with collimator on, detector two (D2) was used. Two different set-ups were used; in the first one; the gamma camera holder was used, which moved out until the centre of the detector, and the radioactive patient's dose (the source) was placed into the holder, then the detector moved toward the source as close as possible.. In the second one, the pallet was used to handle the source. The table height was 70 cm and the distance between the pallet and the detector was also as close as possible.

The <sup>99m</sup>Tc source was prepared and imaged using 3 ml syringe, under the following protocol: static planar; (total time was 30 seconds, matrix size was 256x256x16, mask was full field of view, and window width was 20%).

The background of the gamma camera was checked by removing all the radiation sources from the camera room and then the background reading was recorded, using the same protocol and the same detector. The background will monitor high reading if there is a contamination in the camera room or any unwanted radioactive source, which can affect the camera reading. The background measurement was repeated after each patient dose reading, if count was the same as the first reading, then there was no contamination. If the reading was different, the camera room needed to be checked for contamination. Also, the sensitivity (S) of the gamma camera was calculated by acquiring an image of point source using <sup>99m</sup>Tc and acquiring background image for 60 seconds, and then interview software was used to calculate the sensitivity of the gamma camera.

The dose calibrator used in this work was sent to the company in Germany for recalibration and then used for this work. Before measuring the activity with dose calibrator, the daily quality control was performed, such as accuracy and linearity. The background of the dose calibrator was recorded after removing all the unshielded radioactive sources from the hot lab, to make sure there is no contamination. After each patient dose, the background was checked, if the reading was the same as the first one, then we proceeded. If not, most probably there was unshielded source or a contamination.

### **Acquiring counts**

To calculate the count rate in kilo counts per second (kcps) in gamma camera, the source was positioned in the centre of the detector using either camera holder or table pallet, which was, closed contact to the detector and the image was acquired according to above-mentioned protocol.

The background was subtracted from the total count rate reading to get the actual count that was used to calculate the activity of the source.

### **Dose calculation**

After acquiring and recording the count rate in the \gamma camera, the dose of the camera was calculated, by subtracting the camera background count (B) from the total count rate of the source (CR) in the acquired image. The actual count reading ( $^{m99}\text{Tc}$ ) of the camera was calculated using the following relation:

$$Tc = CR - B \quad (1)$$

The camera dose (D) was calculated by using the following relation

$$D = Tc/S \quad (2)$$

Where, S is the sensitivity, all patients' doses were calculated by using equation (2). This equation can be used only when the patient dose positioned fix in the detector centre using holder, which does not cause any attenuation. When the patient dose positioned in the pallet which can cause attenuation, the correction factor has to be considered and then equation (2) can be rewritten as following.

$$D = Tc/S + C \quad (3)$$

Where, C is the correction factor. Each material has different correction factor depend on the characteristics of that material.

## Results and discussion

The experiment was performed using  $^{99m}\text{Tc}$ , dose calibrator, gamma camera and 3ml syringe. Different numbers of patient doses were considered. The patient dose was measured with the dose calibrator firstly, and then sent to be measured with gamma camera. Each dose measurements in both instruments, takes less than one minute, so as to avoid the decay factor.

Two gamma camera setups were tested; ten different patient doses were measured from each setup. In the first setup, the source handled with camera holder and in the second setup, the source was placed on the pallet. The same source was measured in the dose calibrator, by putting the source into the well chamber and then displayed reading was recorded. Table 1, shows ten different doses measured with dose calibrator, and also that calculated from the gamma camera in MBq using the holder of the camera. The result shows that there is no significant difference between the dose calibrator readings and the camera readings. Figure 4, illustrates the results of doses measured via camera and the dose calibrator. The figure shows that, the two doses measured from both equipments were the same, the differences were very small. Although there was slight difference in gamma camera reading, but this difference was very small and cannot affect on the dose reading, and can be neglected when converted to mCi, even this difference is lower than the background of dose calibrator. Most probably this small difference is caused by variation on the electronics circuits or in the position of the source.

**Table 1: The dose measured using dose calibrator and gamma camera, the source in the holder**

Dose calibrator measures (MBq)	Gamma camera measures (MBq)	Difference (MBq)
59.385	59.372	0.0123
28.956	28.932	0.0240
27.417	27.399	0.0175
44.067	44.045	0.0217
29.008	28.994	0.0130
122.20	122.168	0.032
114.01	113.986	0.024
133.00	132.989	0.011
140.00	139.976	0.024
125.21	125.179	0.031



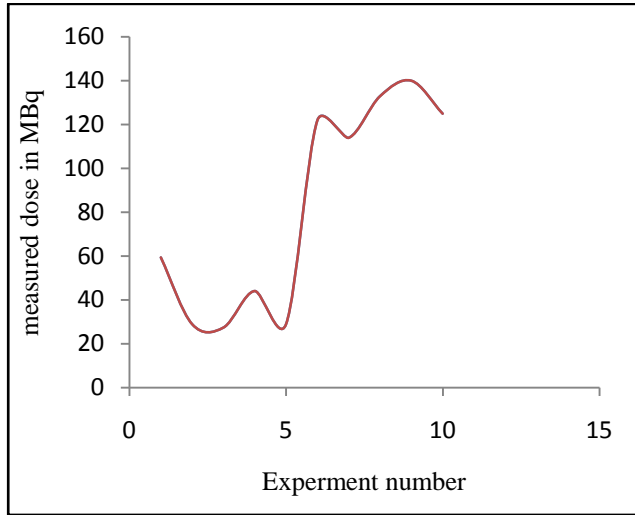

**Figure 4: The relationship between doses measured from gamma camera holder and dose calibrator**

In the second experiment, each dose was measured in the camera by placing the source on the pallet, and the pallet was positioned in the middle of the detector, then the camera count rate was recorded, also the same dose was measured in the dose calibrator, then the reading was recorded. The result of ten patients' doses reading was shown in table 2. The result shows that there was a difference in reading between the dose calibrator and the camera. The difference in all readings was in the range of 0.700 - 0.783 MBq (The mean was 0.744 MBq). This difference was due to the attenuation that was caused by the pallet material. So these differences represent a correction factor (constant C). The correction factor varied according to the type of the material that used to hold the patient dose. The correction factor for the pallet manufactured by Mediso Company was 0.744. Figure 5, illustrates the dose measured via camera and dose calibrator when the source is placed on the pallet. The result showed that there was a difference between the dose measured in dose calibrator and that measured with camera; this difference was due to the attenuation caused by the pallet.

When the camera holder was used, the result of the experiment gave the same reading, which did not cause attenuation of the radiation; the attenuation correction factor has to be considered when the source positioned into the pallet.

**Table 3:** The dose measured using dose calibrator and gamma camera, the source in the pallet

Dose calibrator measures (MBq)	Gamma camera measures (MBq)	Difference (MBq)
53.390	53.649	0.7706
53.206	52.428	0.7774
18.981	18.273	0.7082
31.302	30.597	0.7045
77.700	77.000	0.7000
134.00	133.208	0.791
120.00	119.272	0.728
112.00	111.233	0.767
127.00	126.219	0.781
130.00	129.217	0.783

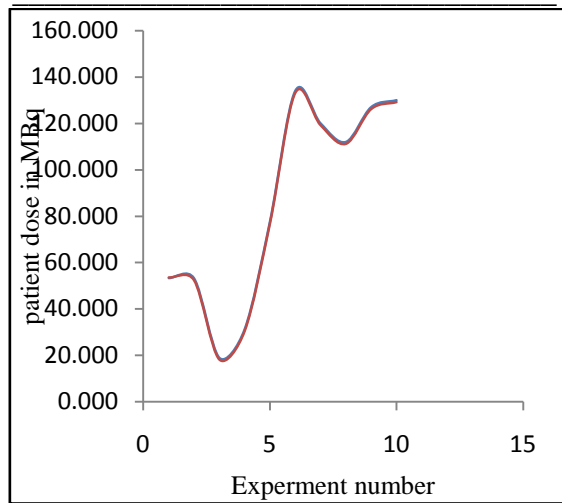

**Figure 5:** The relationship between doses measured from gamma camera pallet and dose calibrator

The decay for both measurement methods was calculated by considering only one dose and measured each hour for six hours, the result illustrated in figure 6. The result showed that the decay in the dose calibrator was the same as that from the gamma camera, and the dose activity decreased as the time increased according to decay law.

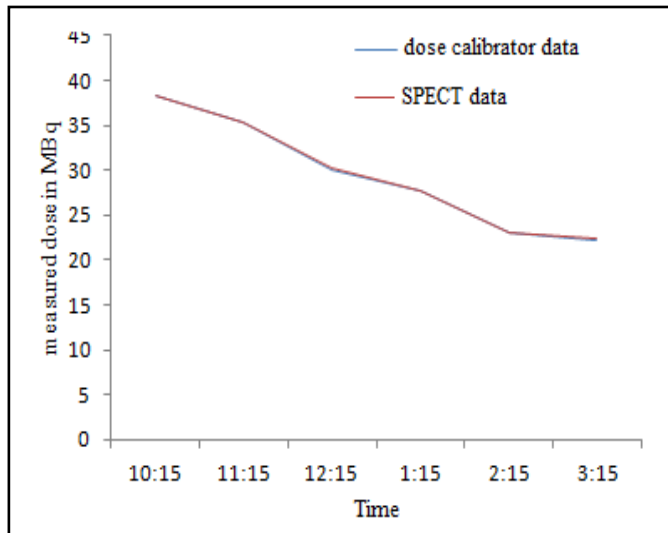

**Figure 6: The decay in gamma camera and dose calibrator**

The performance of the proposed method was evaluated by using two different performance measurements, the accuracy and the correlation coefficient.

Accuracy was checked by calculating the mean, SD and of camera readings and dose calibrator readings, then dividing the mean of camera by mean of dose calibrator readings, and then multiplied the result by 100.

The means of measured source with dose calibrator and gamma camera (the source positioned in holder) was calculated. The mean of dose calibrator reading was 82.33 and the mean of camera reading was 82.30, and The accuracy was 99.97%; the difference between the two mean (bias) was only 0.03. Beside the mean, the standard deviation (STD) was calculated. The STD of dose calibrator reading was 48.33 and the STD of camera reading was 48.33, there was no difference between the two readings.

The mean of the source measured with camera (source in the pallet) and dose calibrator was 85.110 and 85.758 respectively, the difference or bias was 0.648. The STD was 43.920 and 44.025 respectively, the difference was 0.105. The difference in the second setting was higher than in the first setting because the correction factor wasn't considered, and when considering the correction factor, the camera reading gave the same reading that was obtained by dose calibrator.

The second method for performance evaluation was correlation coefficient, the result shows that the correlation coefficient ( $r$ ) was 1, and this indicated that the proposed method for the source measuring gave the same reading that was given by dose calibrator. The linear correlation coefficient charts for the two experiments are illustrated in figure 7 and figure 8.

According to the above results, the patient dose can be measured by using the camera by positioning the dose either in the holder or on the pallet. When pallet is used, the correction factor has to be considered. Thus, to measure the patient dose with camera, we recommend that, to use the camera holder instead of positioning the source on the table pallet to avoid the correction factor

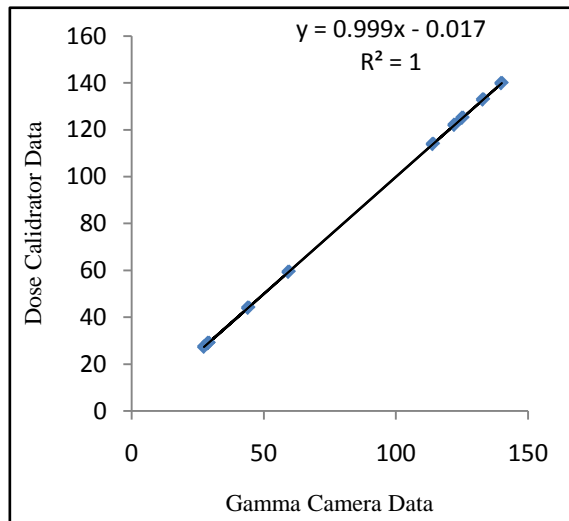

**Figure 7: Correlation coefficient between does calibrator and gamma camera (Source on the holder) data**

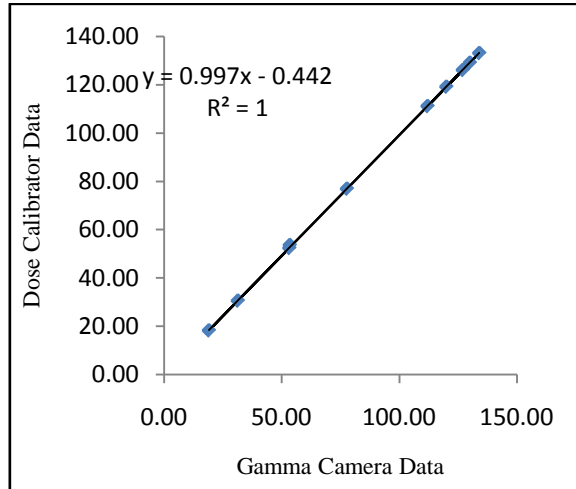

**Figure 8: Correlation coefficient between does calibrator and gamma camera (source on the pallet) data**

### **Conclusion:**

The proposed method for radioactive source or patient dose measurement based on SPECT gamma camera has been demonstrated. Different patient dose has been tested, using two different source positions, in camera holder and on table pallet. When reading of dose calibrator and that taken from the holder of the camera was compared the result showed that two readings were the same. When pallet used for positioning the patient dose, the correction factor needs to be added or subtracted to the gamma camera reading. The correction factor depends on the material of the pallet. The decay of the source measured with both gamma camera and dose calibrator at different time, is the same. The accuracy of the proposed methods was calculated, and the result showed that, it is possible to get accuracy up to 99.97 %. Beside the accuracy, the correlation was calculated, and the result shows that, there is no difference between the two readings; the correlation coefficient (r) was 1. The SPECT gamma camera was successfully used for patient dose measurements and gave same readings as that obtained via dose calibrator. Thus, the proposed method can be used in the department of nuclear medicine to measure the patient dose accurately and within no time, without going

back to the dose calibrator. The proposed method was tested and verified by using actual patient doses.

## **References:**

1. International Atomic Energy Agency, "Quality control of nuclear medicine instruments", TECDOC-317, 1984.
2. D. Bernier, et. Al. "Nuclear medicine Technology and Techniques," 4<sup>th</sup> edition, Mobsy, USA, 1997.
3. S. Cherry, J. Sorenson, M. Phelps, "Physics in nuclear medicine," 3<sup>rd</sup> edition, Elsevier, California-USA, 2003.
4. J. Bushberc, et.al, "The Essential Physics of Medical Imaging", 2<sup>nd</sup> edition, New York, wolter kluwer, 2002.
5. A. Kantzas, "Application of Gamma Camera and SPECT System in Chemical Process", Chemical Engineering Journal, vol. 77(1-2), pp:19-25,2000.
6. M. Brogert, "Basic of SPECT, PET and PET/CT imaging", JASS 2006.
7. Cuocolo et.al, Pest practice in nuclear medicine part 2, European Association of Nuclear Medicine, 2007.
8. M. Groch and W. Erwin, "SPECT in the Year 2000: Basic Principles", J Nucl Med Technol, vol. 28, pp. 233 – 244, 2000.
9. S. Elbert, Distance Assisted Training Program for Nuclear Medicine Technology, Instrumentation – part 1, Dose Calibrator, IAEA -1997.